

4' Tall 1" Spaced 6" Wide Picket Dog Eared

Lincoln

installed 0"-2" off ground

98" (POST CENTERS)

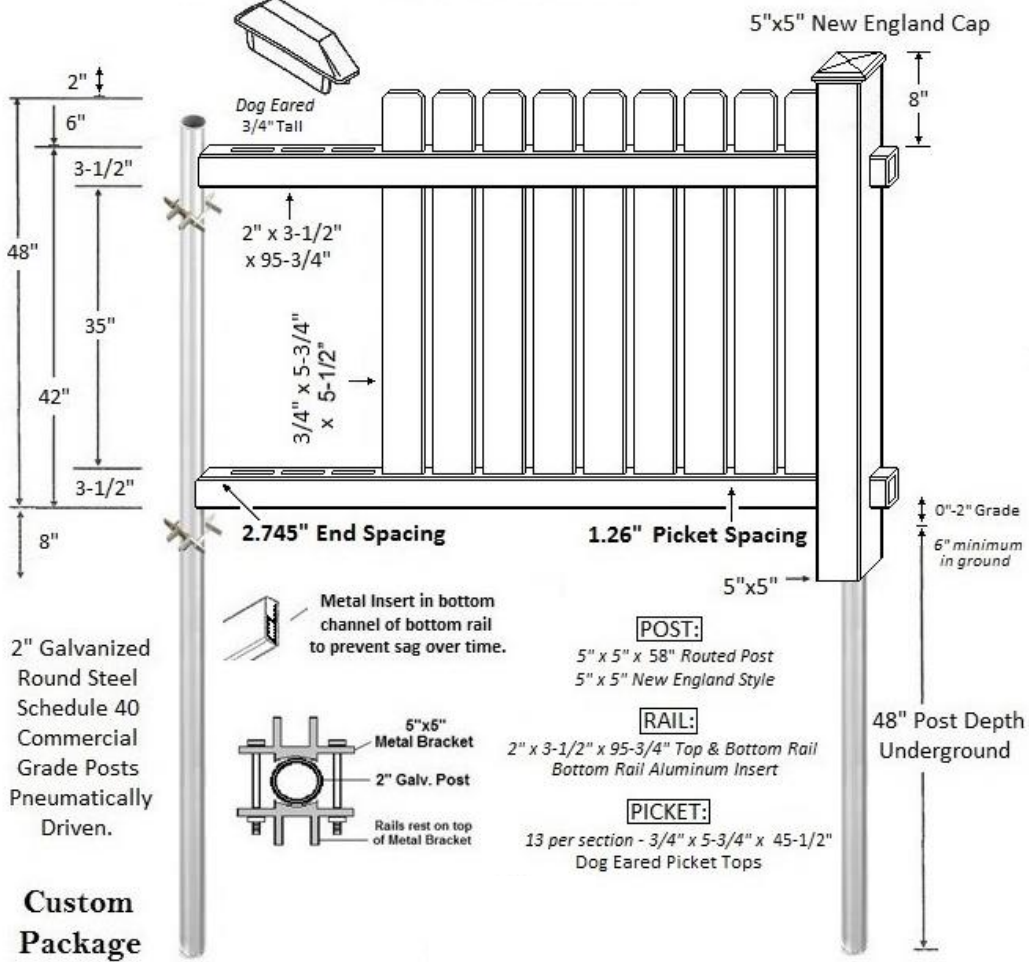

2" Galvanized Round Steel Schedule 40 Commercial Grade Posts Pneumatically Driven.

Custom Package

- POST:**
5" x 5" x 58" Routed Post
5" x 5" New England Style
- RAIL:**
2" x 3-1/2" x 95-3/4" Top & Bottom Rail
Bottom Rail Aluminum Insert
- PICKET:**
13 per section - 3/4" x 5-3/4" x 45-1/2"
Dog Eared Picket Tops



PVC
4' Tall 2" Spaced 3" Picket Dog Eared

Madison

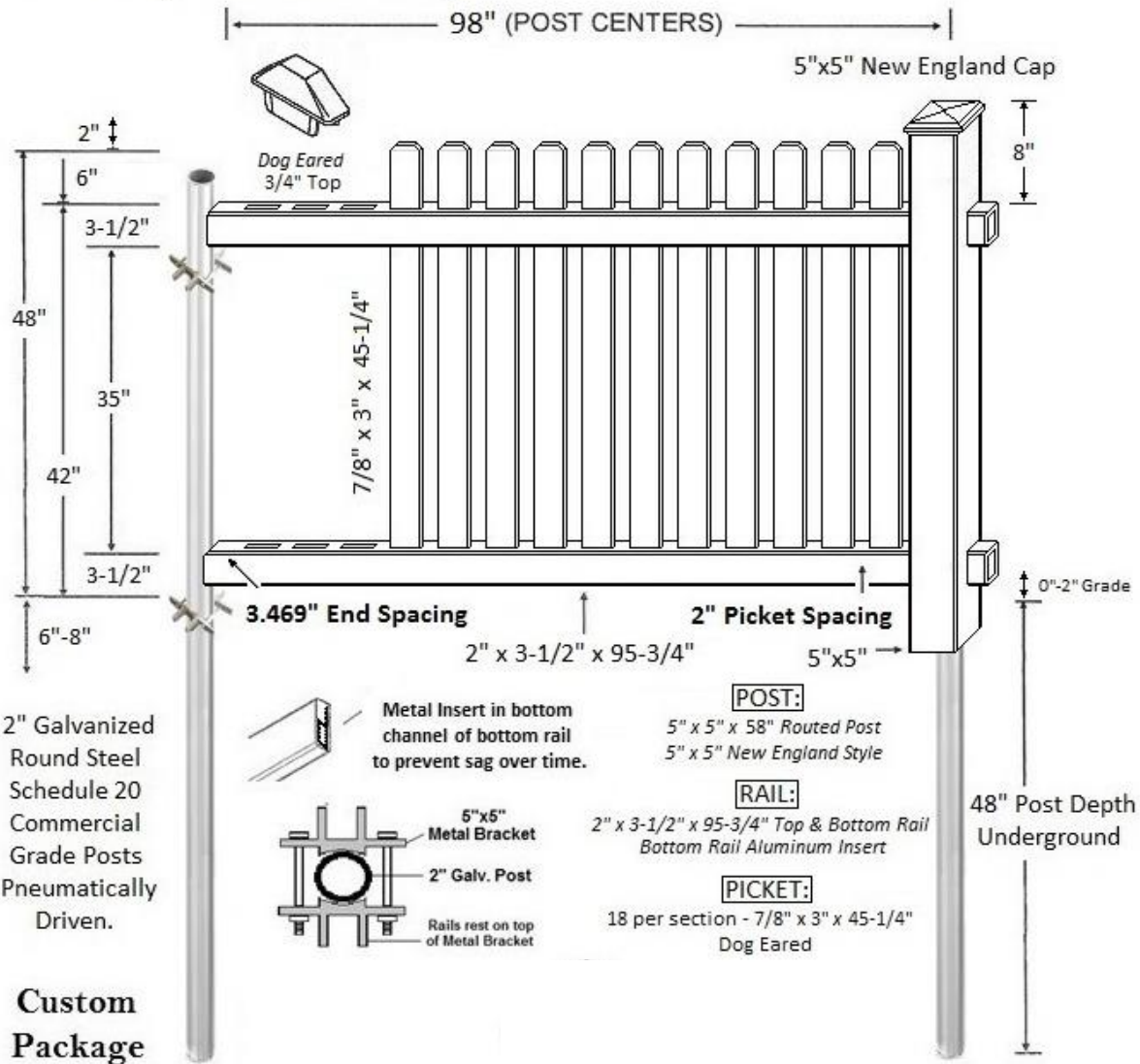

PVC
4' Tall 2" Spaced 3" Picket Spade

Franklin

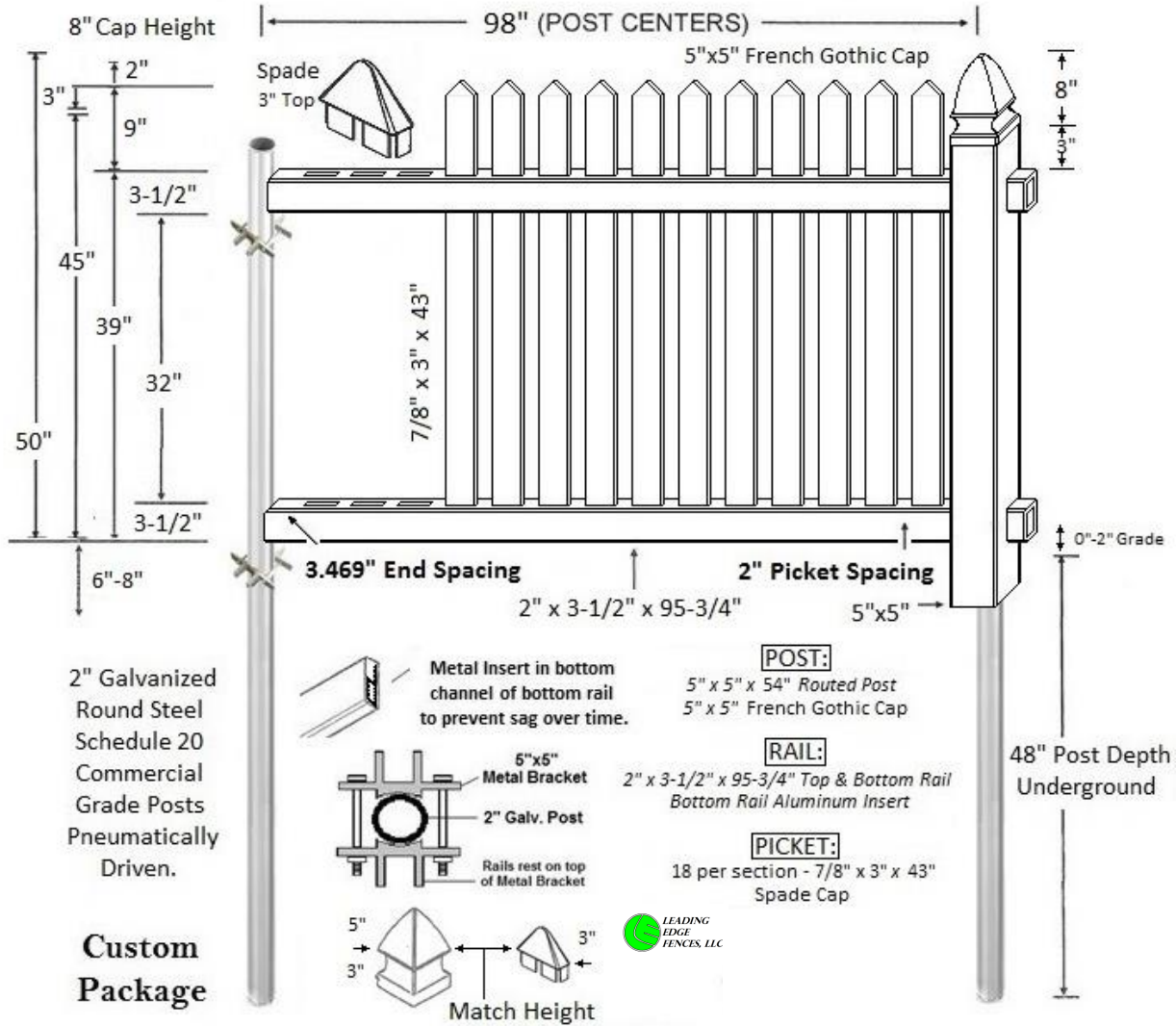

PVC
4' Tall 50/50 1.5" Spaced 1 3/8" Picket

Hamilton

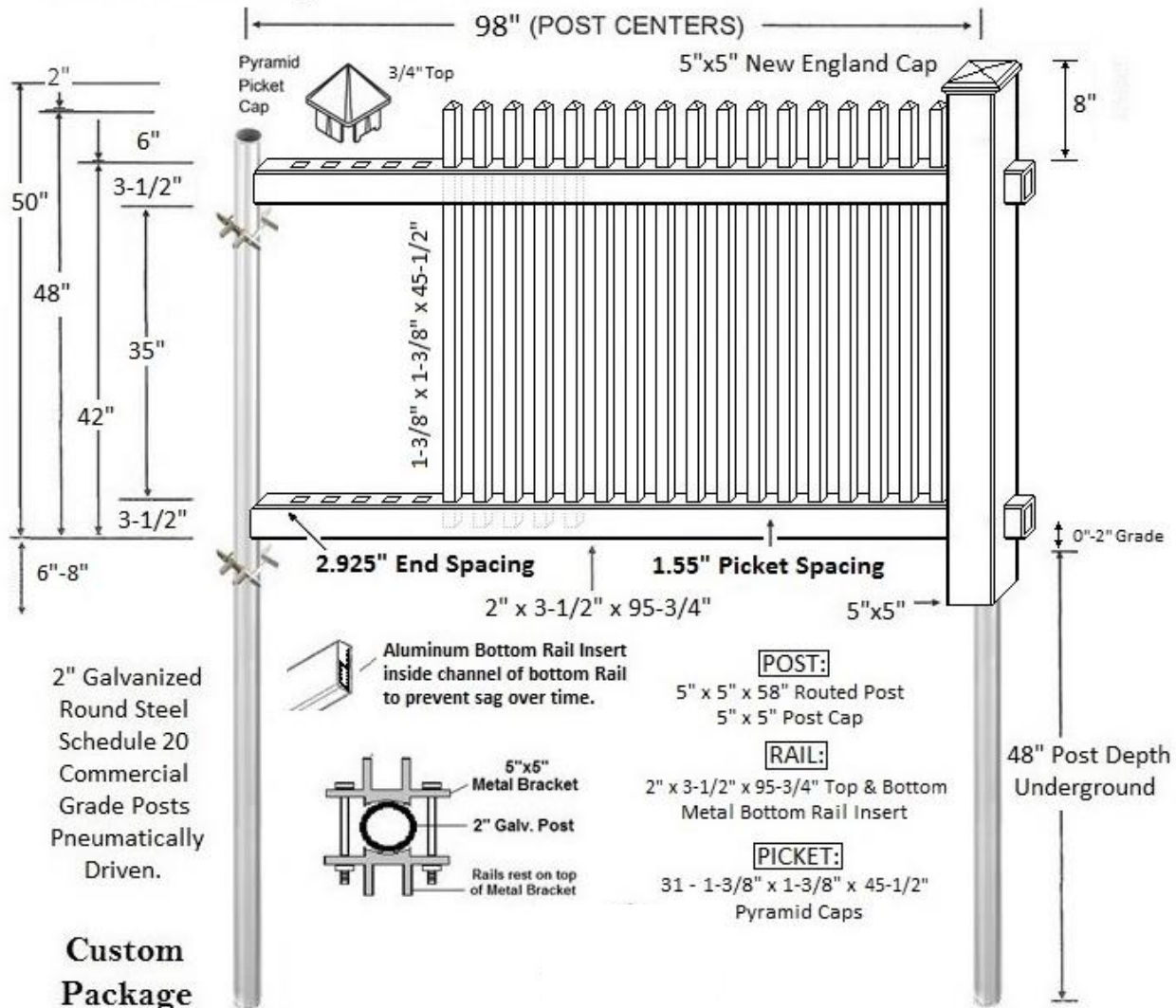

PVC
4' Tall 2" Spaced 6" Wide Picket

Washington

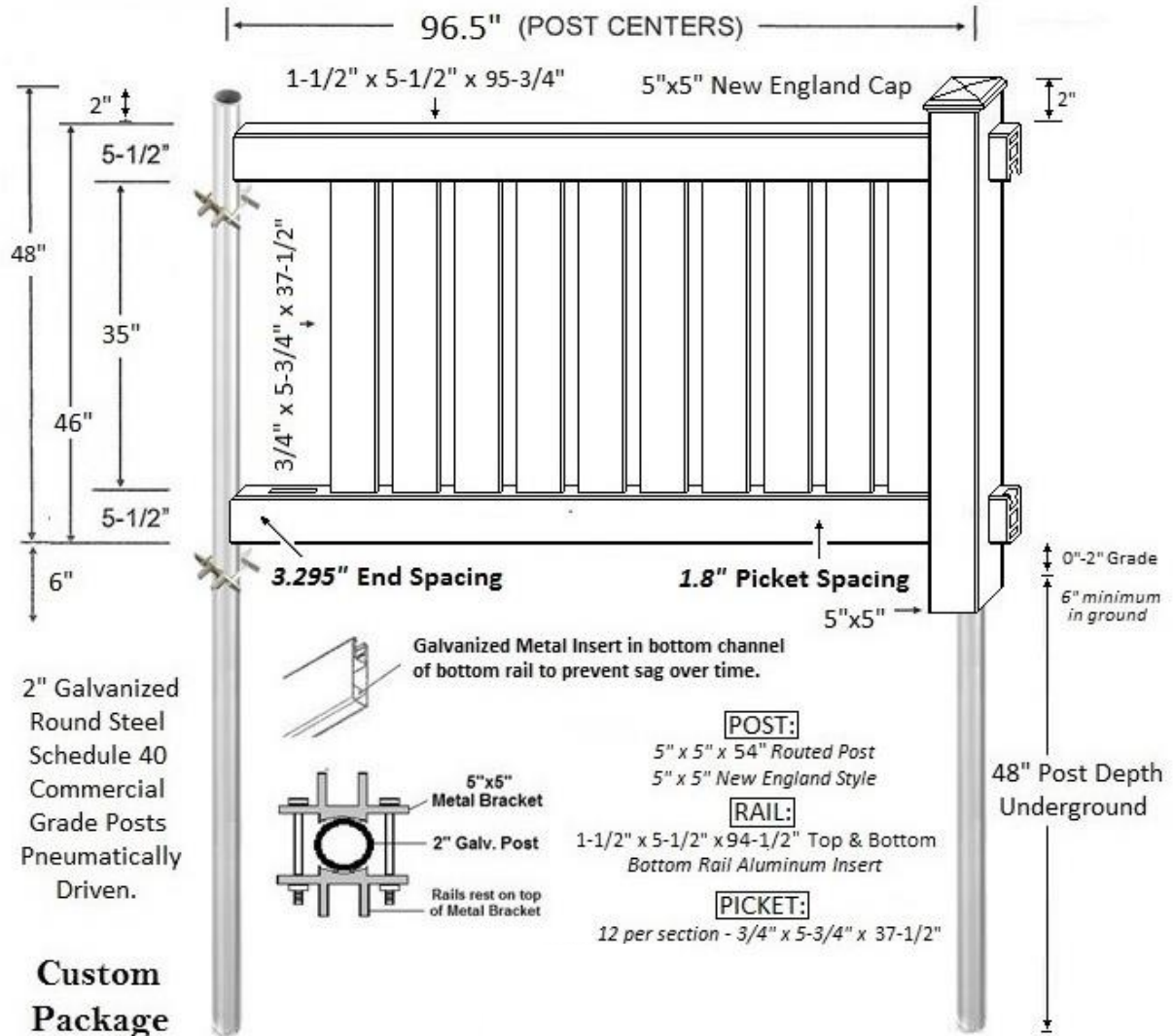

Middleton

4' Tall Solid Prairie Style

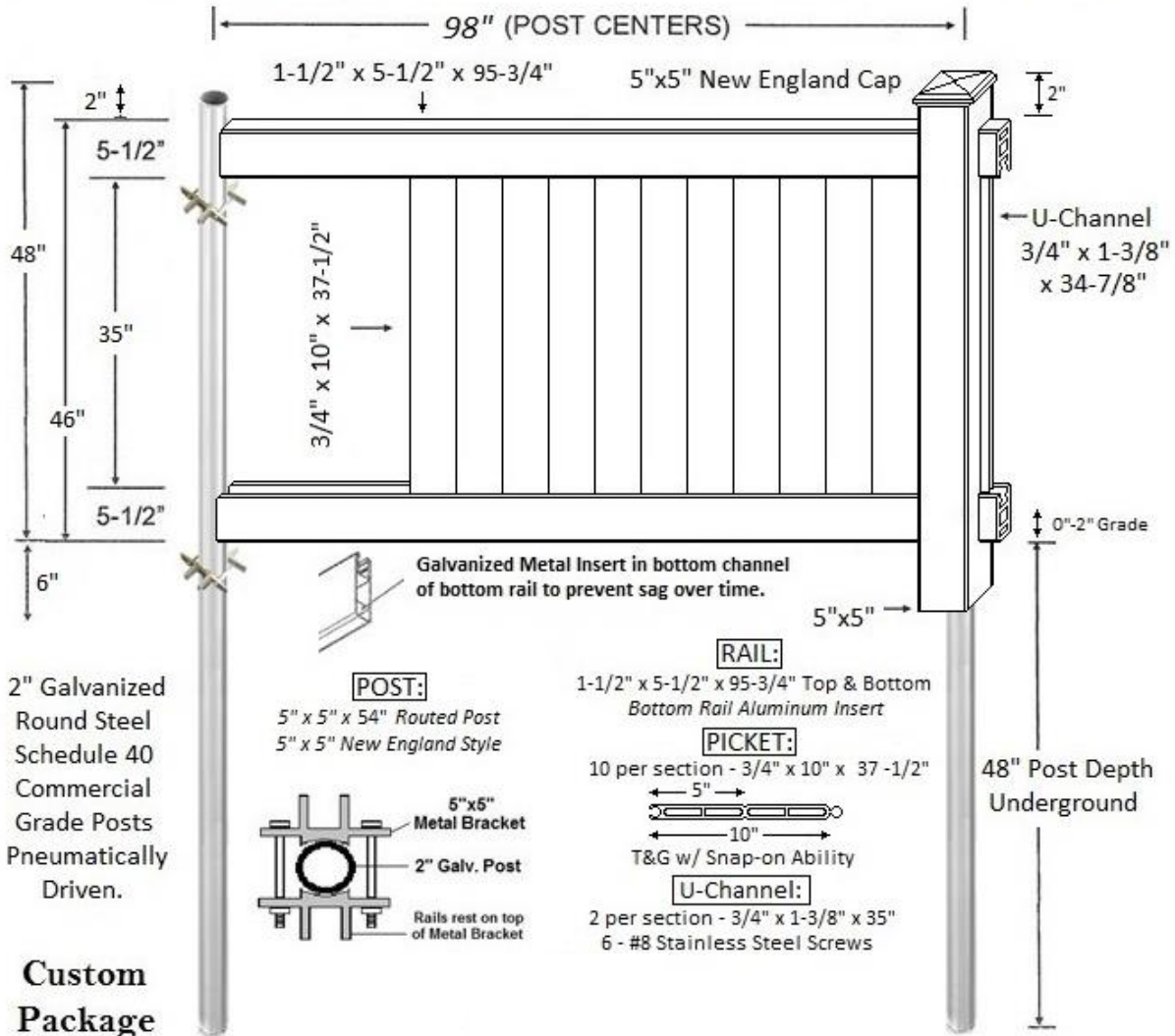

PVC

4' Tall 50/50 1.5" Spaced 1 3/8" Picket

Henry

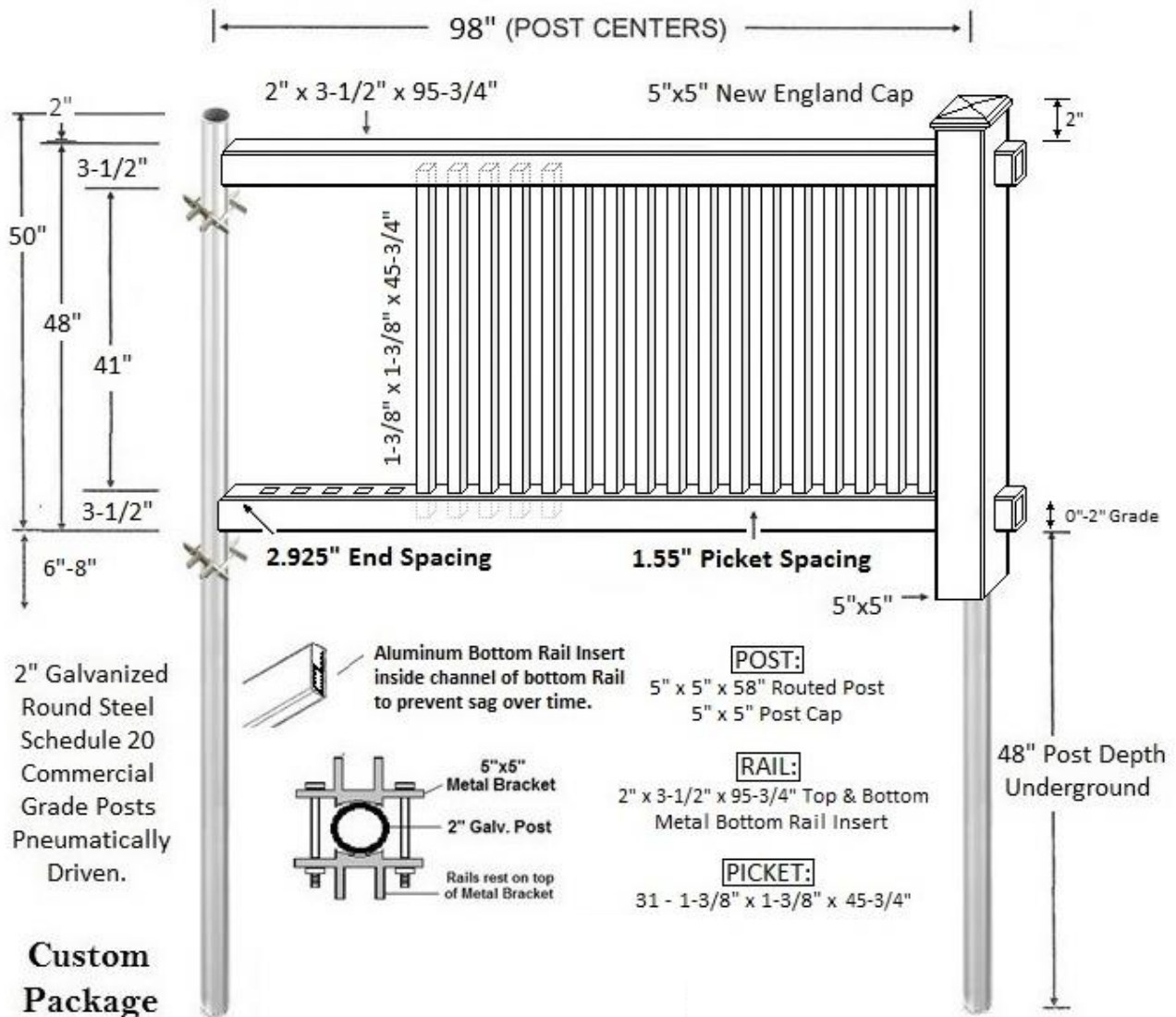

PVC
5' Tall 3 Rail 2" Spaced 3" Picket

John Adams

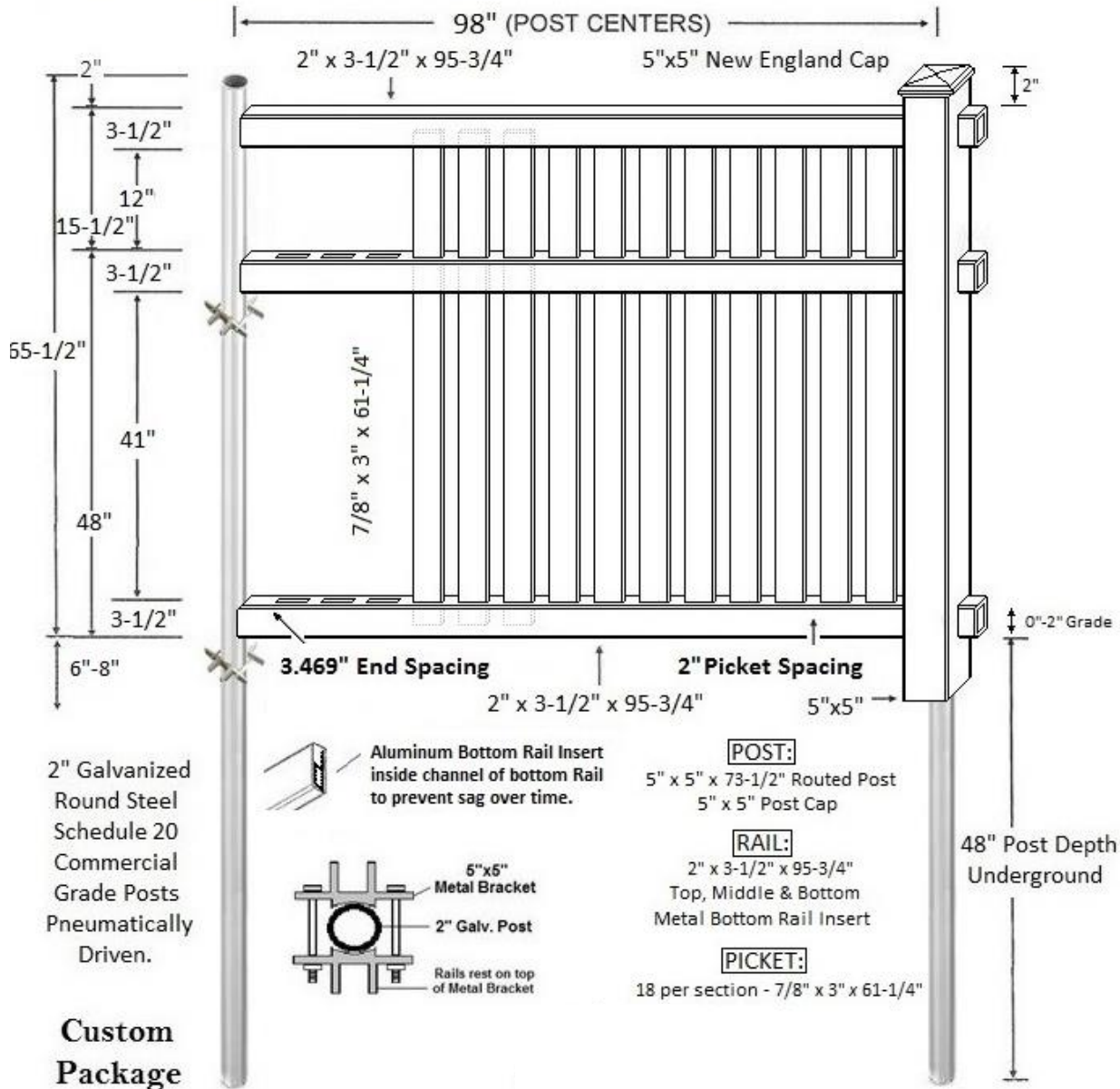

PVC
5' Tall 3 Rail 1.5" Spaced 1-3/8" Picket

Samuel Adams

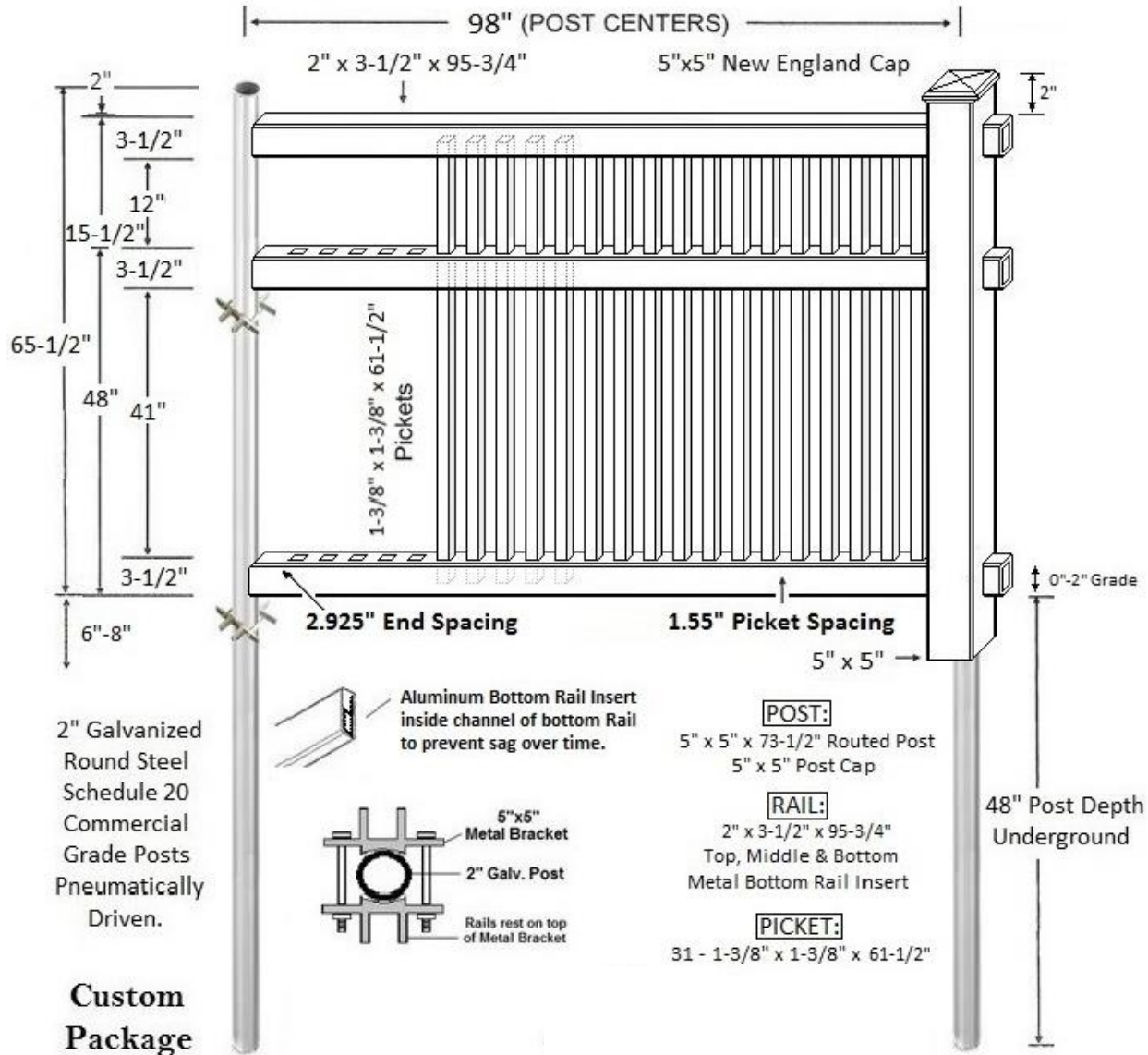

**5' Tall 3 rail 1.5" Spaced 1-3/8" Picket
w/ ladder lattice on top**

Mason

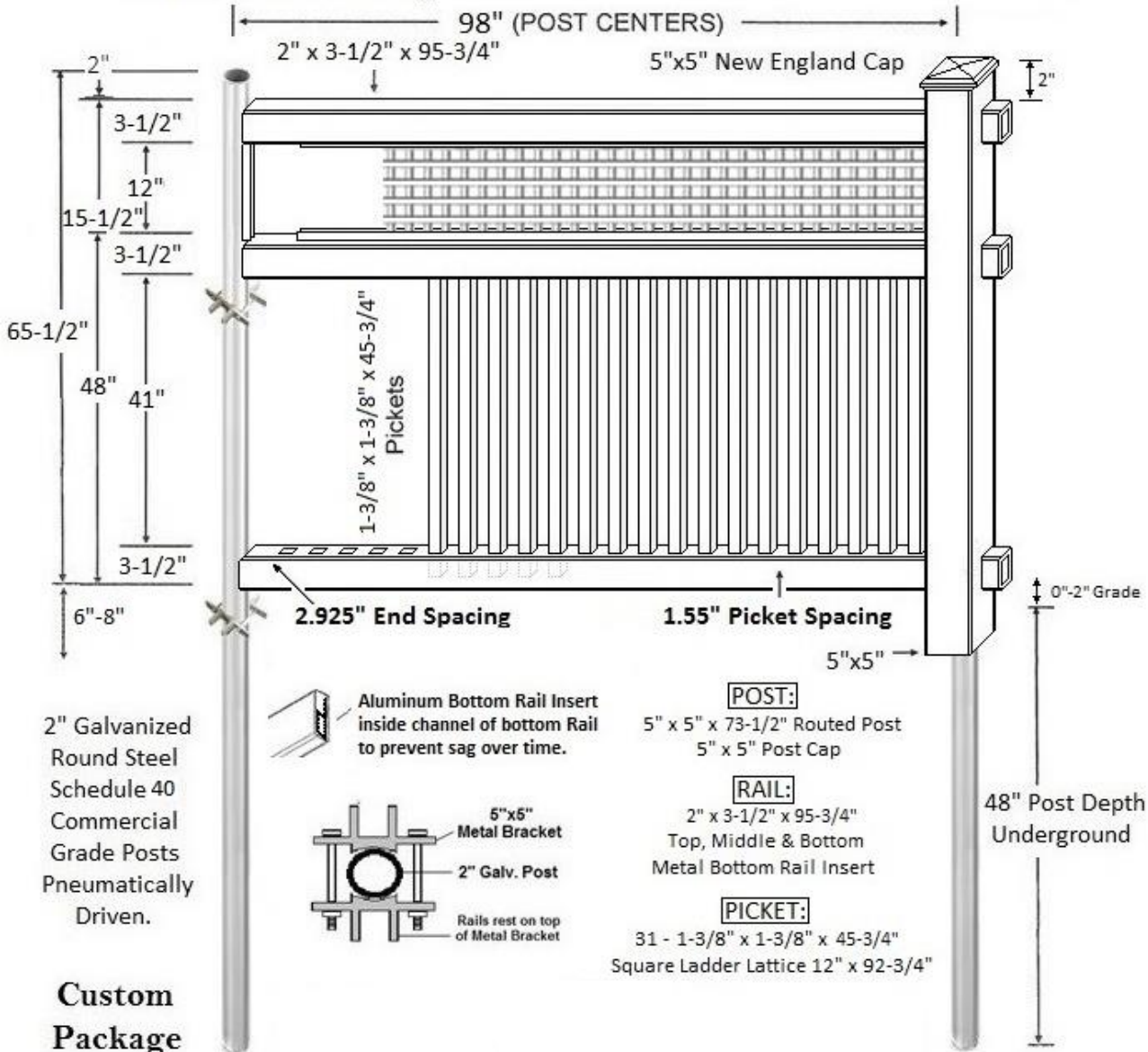

PVC
 5' Tall 3 rail 1.5" Spaced 1-3/8" Picket
 w/ diagonal lattice on top

Marshall

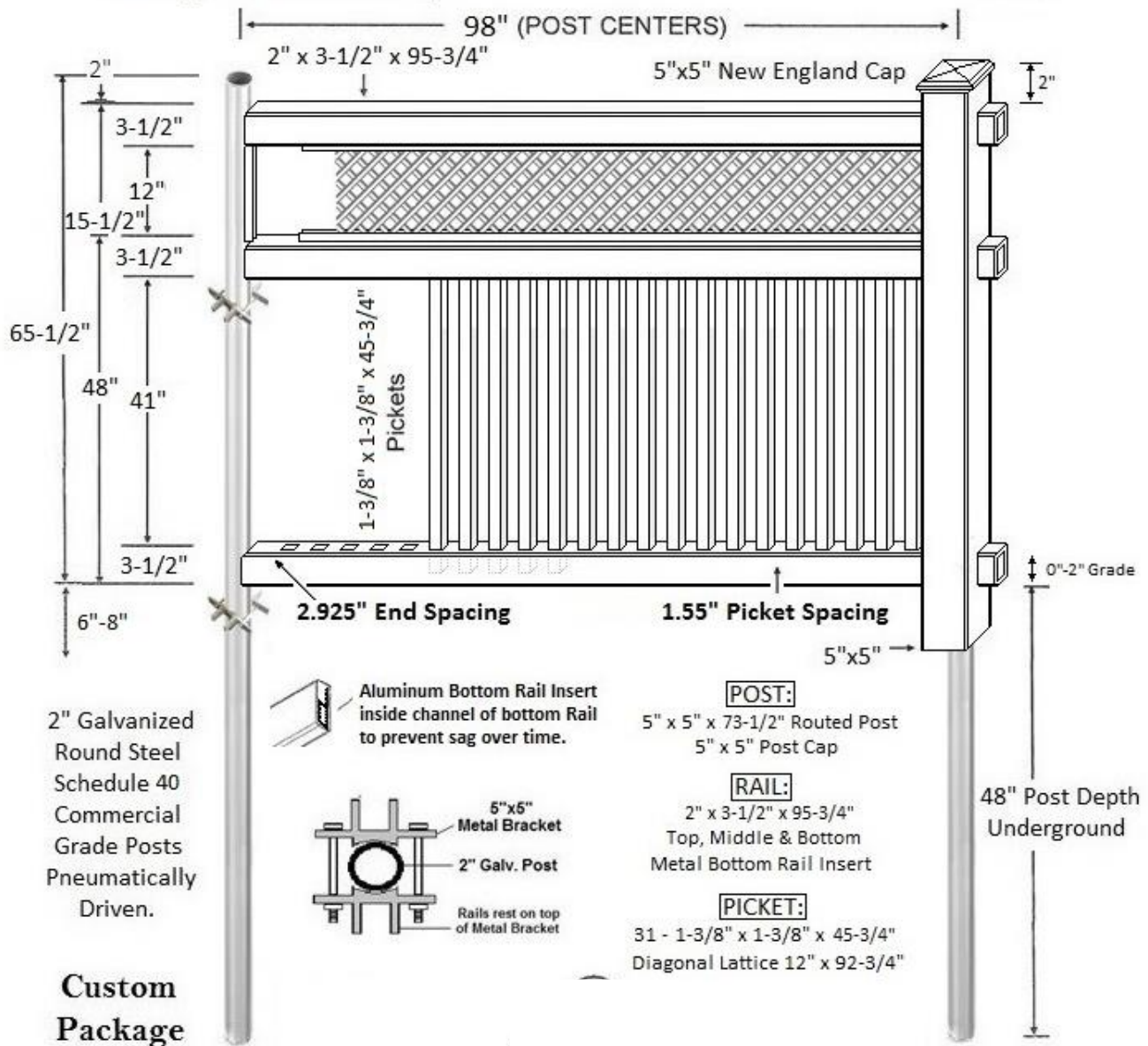

Abigail

