

FINAL GRANDVIEW COMMONS FENCING GUIDELINES

REVIEW MEETING: MARCH 17, 2003

ADDENDUM I • FENCING GUIDELINES

FENCING

The Architectural Review Committee shall approve fence design and locations. The City of Madison Ordinances supercede all information contained in these guidelines. Fencing is not required.

Type I Fencing shall be used in the front yard area from the front property line to the home's prominent back corners, see "Type I Fencing Styles". Type I fencing shall be 42" in height to the top rail. On property type "C", Type I fencing is the required style for use throughout the property. On property types "A" and "B", Type I fencing may be used throughout the property.

Type II Fencing may be used in the rear yard area on property types "A" and "B" only, see "Type II Fencing Styles". The rear yard shall be defined as the area from the rear property line to the home's prominent back corners. Type II fencing shall be 60" in height to the top rail. The Type II fencing style shall be consistent with the Type I fencing style selected for the property.

Side Yard Fencing: The side yard shall be defined as the area between the home's front and back corners; Type I fencing styles shall be used in this area. Fencing may cross but shall not be placed along or in use easements.

Cornerposts

- Cornerposts on Type I fencing shall be spaced a maximum of 72" on center and a maximum of 96" on center on Type II styles. All cornerposts shall have terminating caps or finials at the top; see "Cornerpost Styles" for appropriate options.
- Cornerposts shall be between 4" and 6"(nominal) square, 48" in height on Type I fences and 64" in height on Type II styles.
- Rails shall be discontinuous and abut into cornerposts.

Placement

All fencing shall typically be set back 6" from the property line.

See "Fencing Placement" on pages 3-5 for appropriate and inappropriate locations as well as set back variations.

Materials

- All fencing shall be erected finished side out; i.e. pickets on the outside of the rail, facing the street or neighboring lot.
- Gates are permitted and shall be consistent with the fencing style. Gates in front yards shall be street-facing and open inward. The gate or opening width shall match the sidewalk or walkway width. Openings without gates may be permitted at sidewalks. All openings in use easements shall have gates.
- Fencing shall consist of solid wood with a painted finish.
- Fencing colors shall match the lighter of the trim or siding color on the home.
- See "Picket Details" on page 2 for sizes and spacing. Spacing will vary based on site installation requirements. Picket heights will vary based on the fencing style. Pickets on Type II fencing shall be discontinuous to the middle and top rails.

TYPE I FENCING STYLES

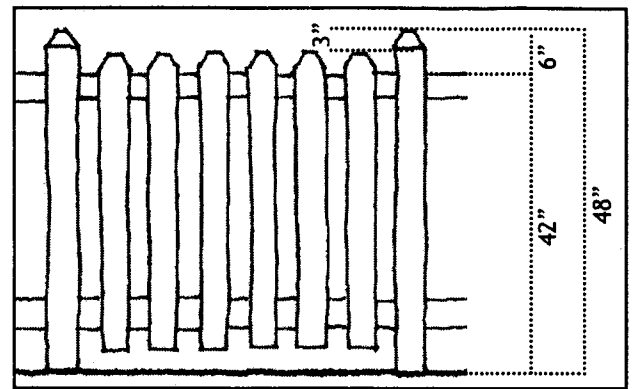

Board

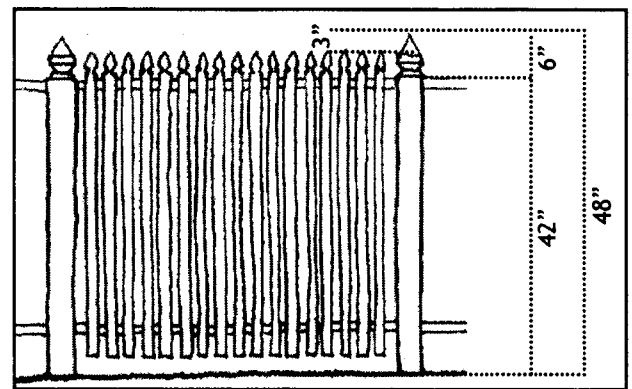

Picket

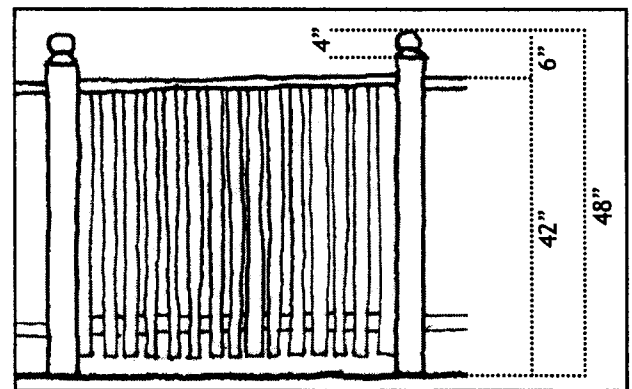

Rail

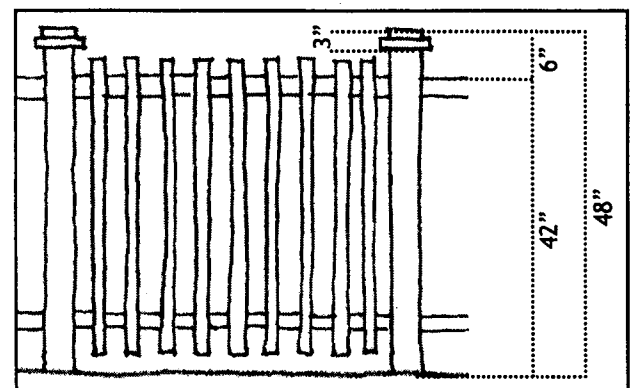

Stick

CORNERPOST STYLES

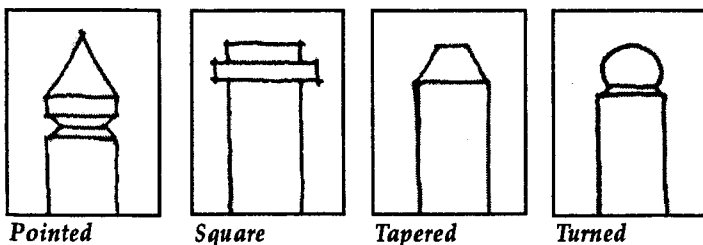

TYPE II FENCING STYLES

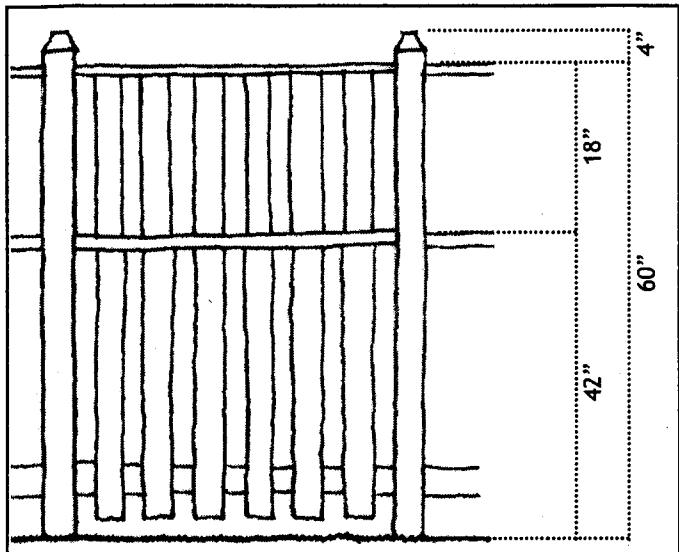

Board

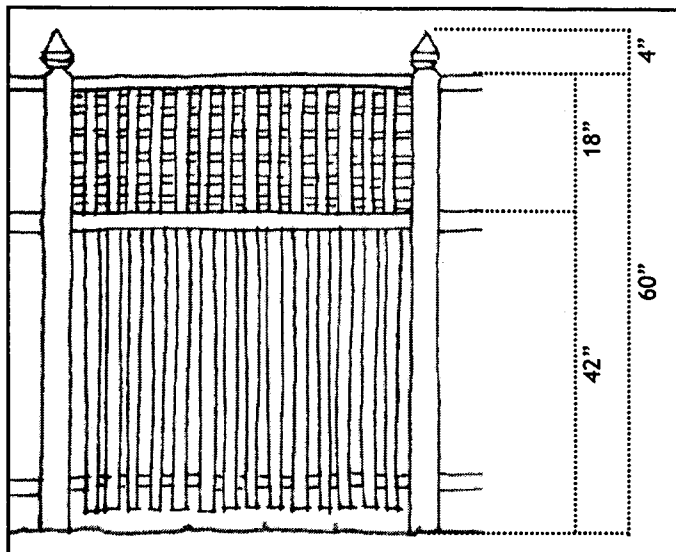

Picket: Lattice shall be 1 1/2" in width with 2" spacing between vertical and horizontal members.

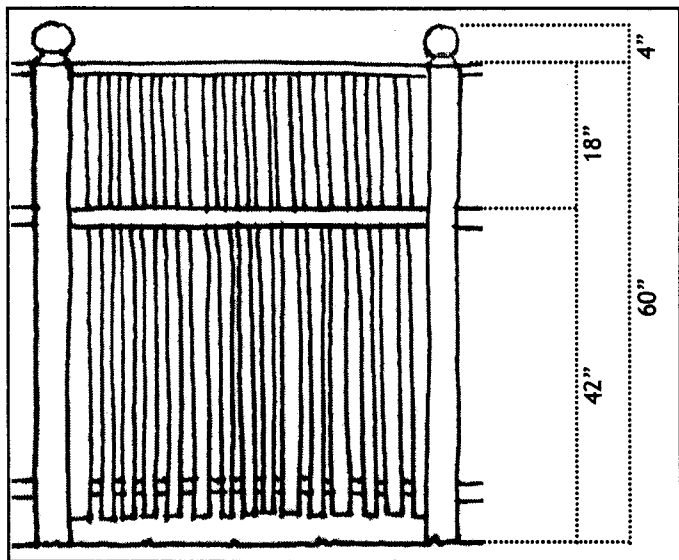

Rail

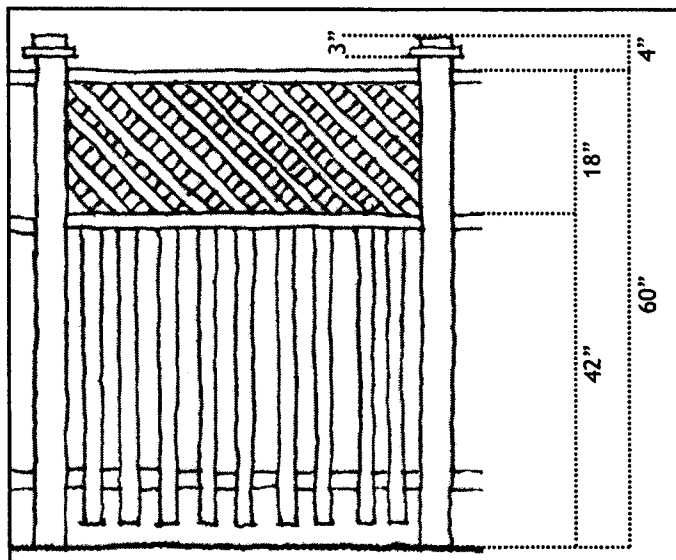

Stick: Lattice shall be 2" in width with 2" spacing between diagonal members.

PICKET DETAILS

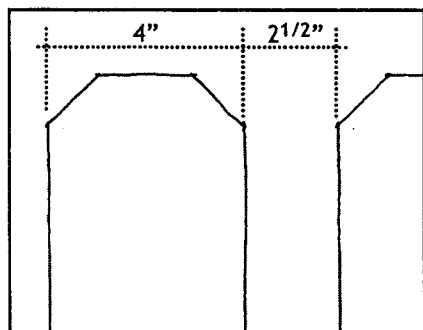

Board

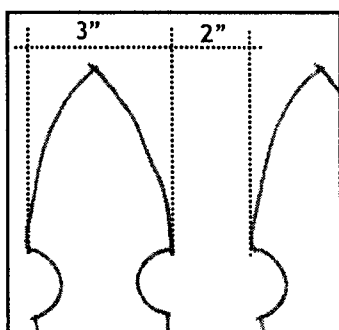

Picket

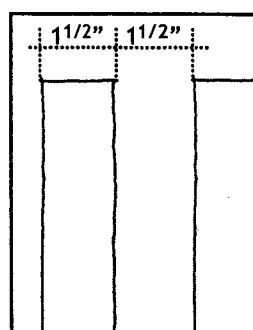

Rail

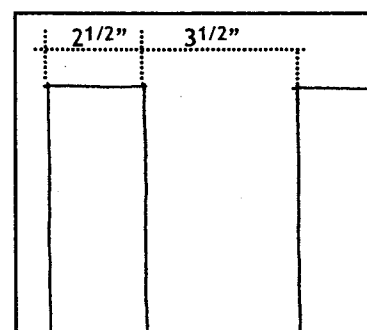

Stick

ADDENDUM I • FENCING GUIDELINES

FENCING PLACEMENT: PROPERTY TYPE A

Street corner or alley corner lot with an alley-loaded garage and use easement.

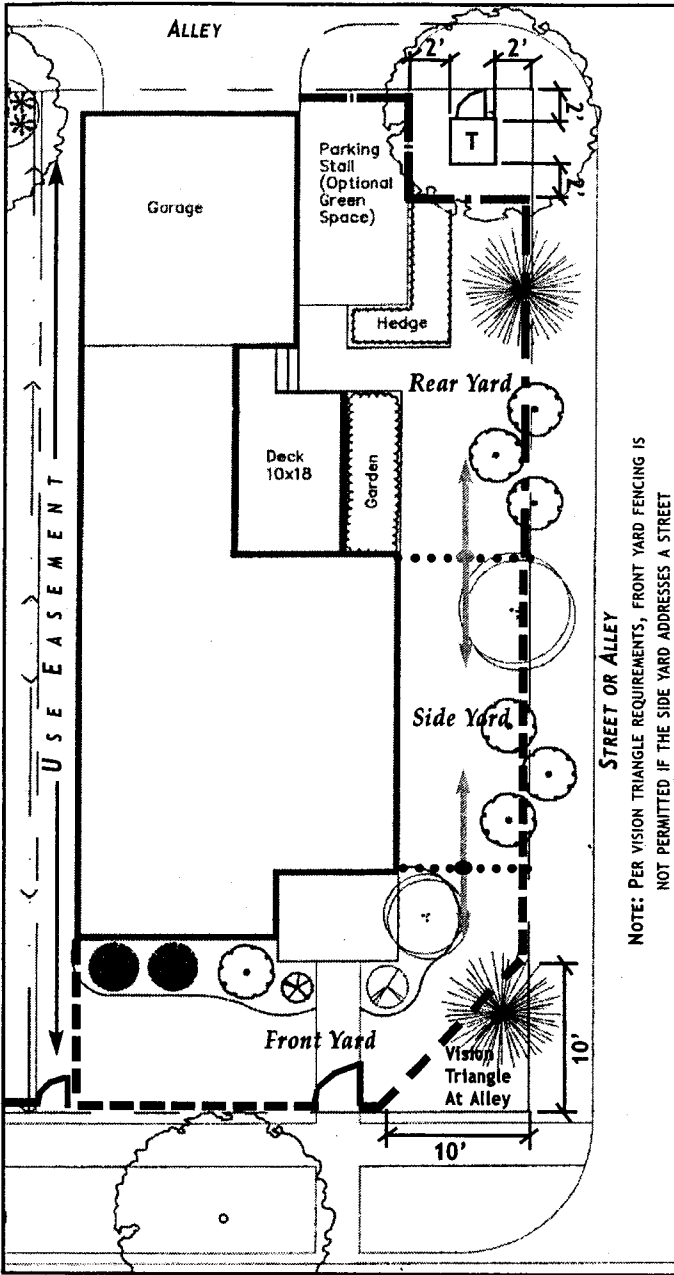

NOTE: PER VISION TRIANGLE REQUIREMENTS, FRONT YARD FENCING IS NOT PERMITTED IF THE SIDE YARD ADDRESSES A STREET

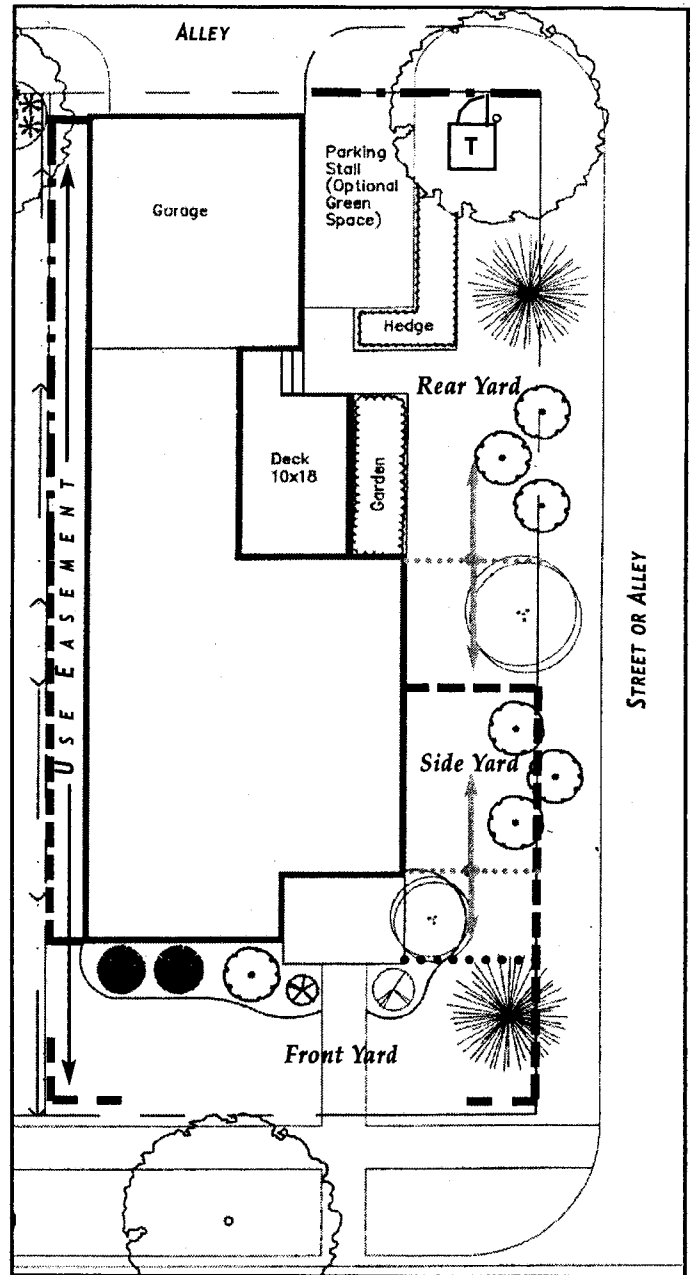

Appropriate:

- Fencing shall meet up with the corners of a home or garage.
- Only one fence is permitted along adjoining properties. The cornerposts of adjoining properties' fencing shall intersect at common corners.
- Fencing within the use easement shall have a gate for the neighboring property owner.
- Fencing at front yards addressing both a main street and an alley shall be set back 10' within the vision triangle.

LEGEND

- Type I Fencing Style
- Type I Fencing Style: Additional Options
- ■ — Type II Fencing Style
- Denotes Side Yard Location Only

Inappropriate:

- Fencing in front yards shall not be permitted when the side yard addresses a street.
- Fencing shall not occur in freestanding segments or be placed arbitrarily.
- Fencing shall not run parallel to non-street-facing or non-alley-facing side yards or use easements.
- Fencing shall not meet up with porch or deck corners.
- **T** Fencing shall not interfere with utility equipment. 10' clearance is required from the opening side of all transformers and a 2' clearance on all other sides. Transformers shall have access gates where appropriate for access from the homeowner's side of the property. Utility pedestals shall have 24" clear on all sides. Current MG&E requirements shall be consulted; whichever is the most restrictive shall apply.

FENCING PLACEMENT: PROPERTY TYPE B

Center lot with an alley-loaded garage and use easement.

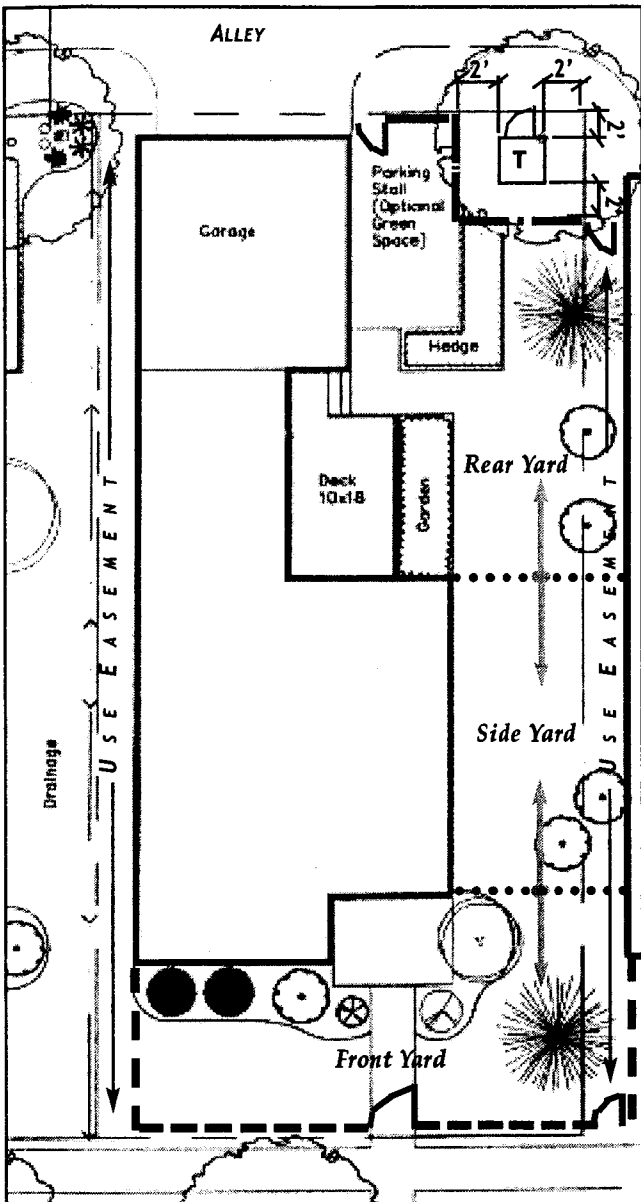

Appropriate:

- Fencing shall meet up with the corners of a home or garage.
- Fencing within the use easement shall have a gate for the neighboring property owner.
- Only one fence is permitted along adjoining properties'. The cornerposts of adjoining properties' fencing shall intersect at common corners.

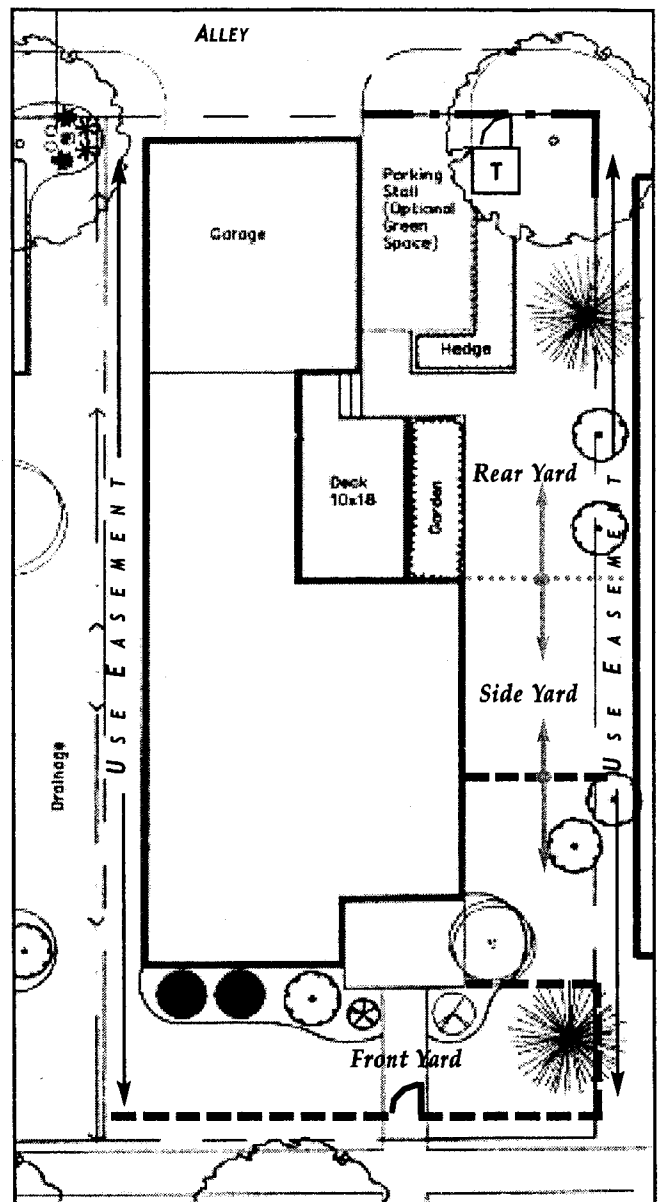

Inappropriate:

- Fencing shall not occur arbitrarily or in freestanding segments.
- Fencing shall not run parallel to side yards or use easements.
- Fencing shall not meet up with porch or deck corners.
- **T** Fencing shall not interfere with utility equipment. 10' clearance is required from the opening side of all transformers and a 2' clearance on all other sides. Transformers shall have gates where appropriate for access from the homeowner's side of the property. Utility pedestals shall have 24" clear on all sides. Current MG&E requirements shall be consulted; whichever is the most restrictive shall apply.

LEGEND

- Type I Fencing Style **-----**
- Type I Fencing Style: Additional Options **.....**
- Type II Fencing Style **— · —**
- Denotes Side Yard Location Only **.....**

ADDENDUM I • FENCING GUIDELINES

FENCING PLACEMENT: PROPERTY TYPE C

Center lot with a street-loaded garage.

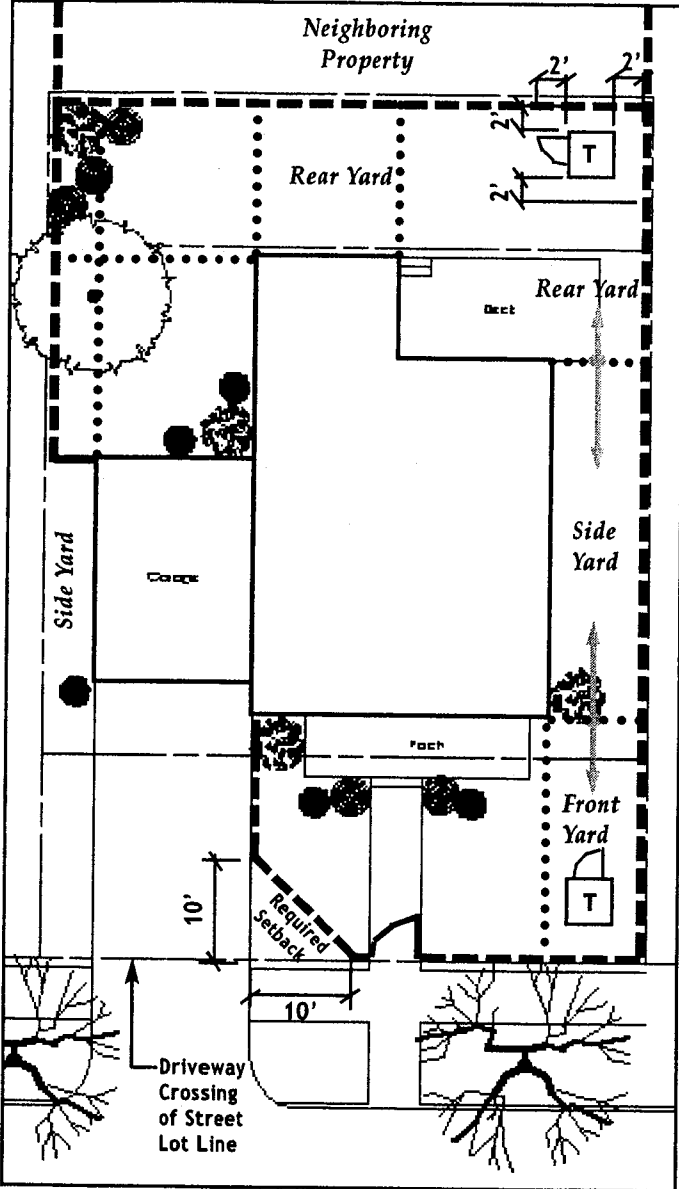

Appropriate:

- Fencing shall meet up with the corners of a home or garage.
- Front yard fencing shall be set back a minimum of 10' from the driveway crossing of a street lot line.
- Fencing may run along side yards and connect to the rear yard.
- Only one fence is permitted along adjoining properties. The cornerposts of adjoining properties fencing shall intersect at common corners.
- **T** Fencing, when located in the front yard, shall screen utility boxes.

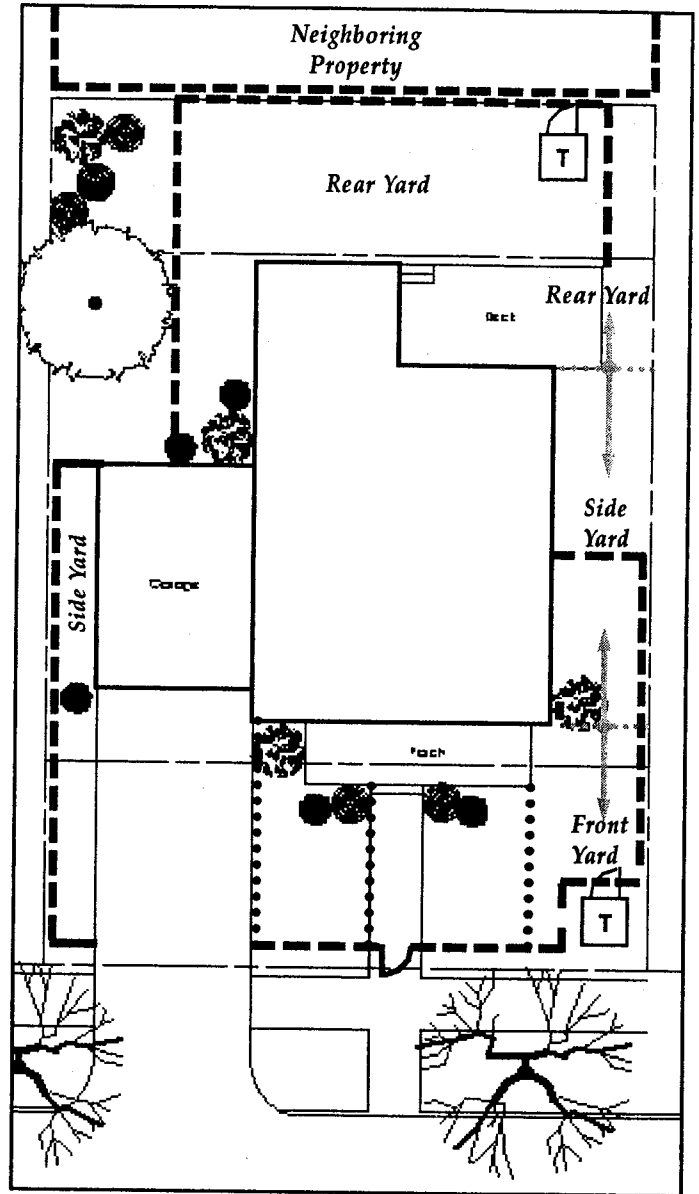

Inappropriate:

- "Type II Fencing" styles shall not be permitted in the rear yard area.
- Fencing may not occur arbitrarily or in freestanding segments.
- Fencing shall not meet up with porch or deck corners.
- Fencing and gates shall not be placed over driveways.
- **T** Fencing shall not interfere with utility equipment. 10' clearance is required from the opening side of all transformers and 2' clearance on all other sides. Transformers shall have gates where appropriate for access from the homeowner's side of the property. Utility pedestals shall have 24" clear on all sides. Current MG&E requirements shall be consulted; whichever is the most restrictive shall apply.

LEGEND

- Type I Fencing Style
- Type I Fencing Style: Additional Options
- Denotes Side Yard Location Only