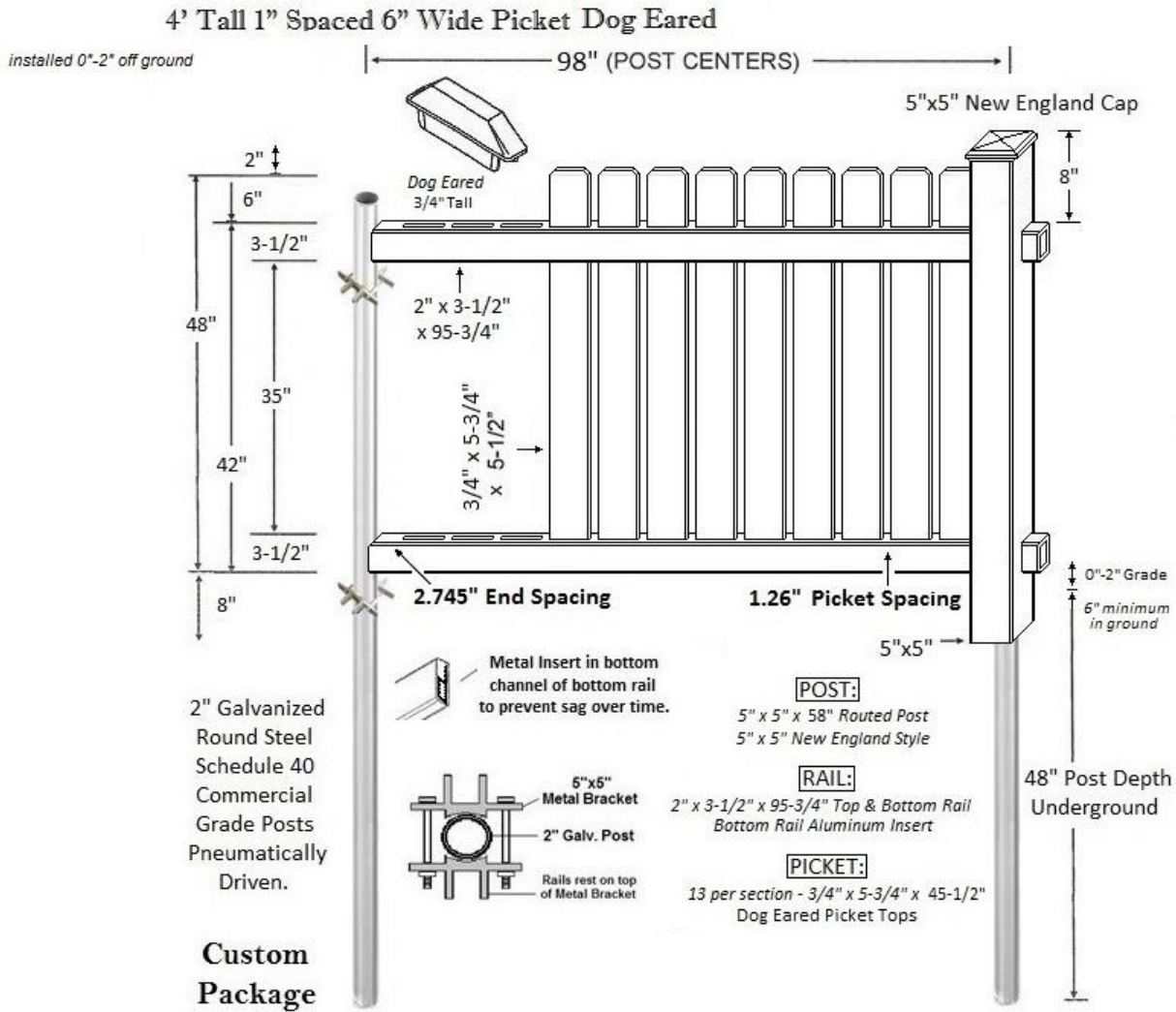

Exhibit E-1



= Lincoln



= Franklin

(Exhibit E-2) PVC
 4' Tall Shadow Box (Board on Board) Dog Eared

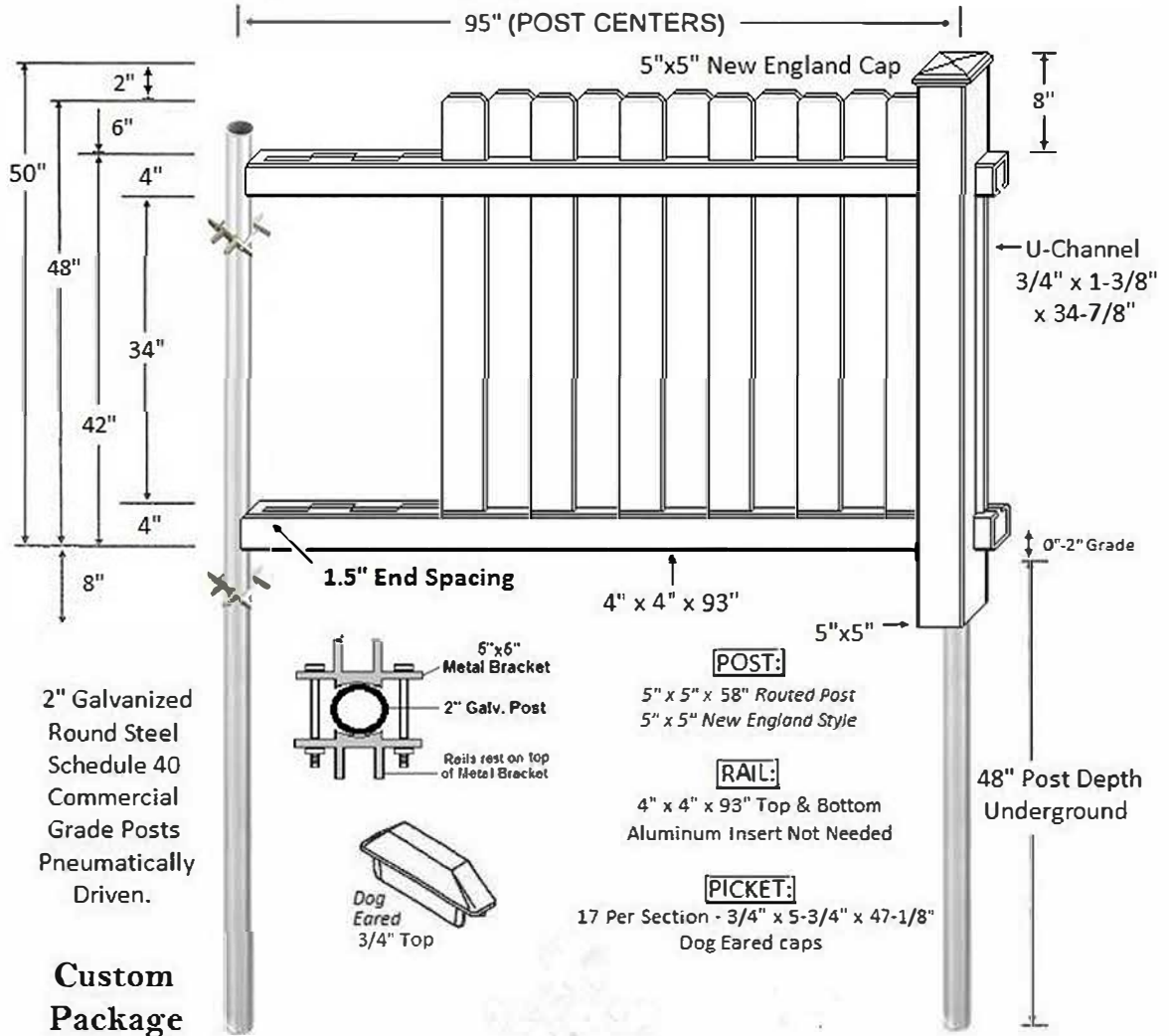

= Jefferson



= Not Available

(Exhibit E-5 type 1 board) PVC
 4' Tall 2" Spaced 3" Picket Dog Eared

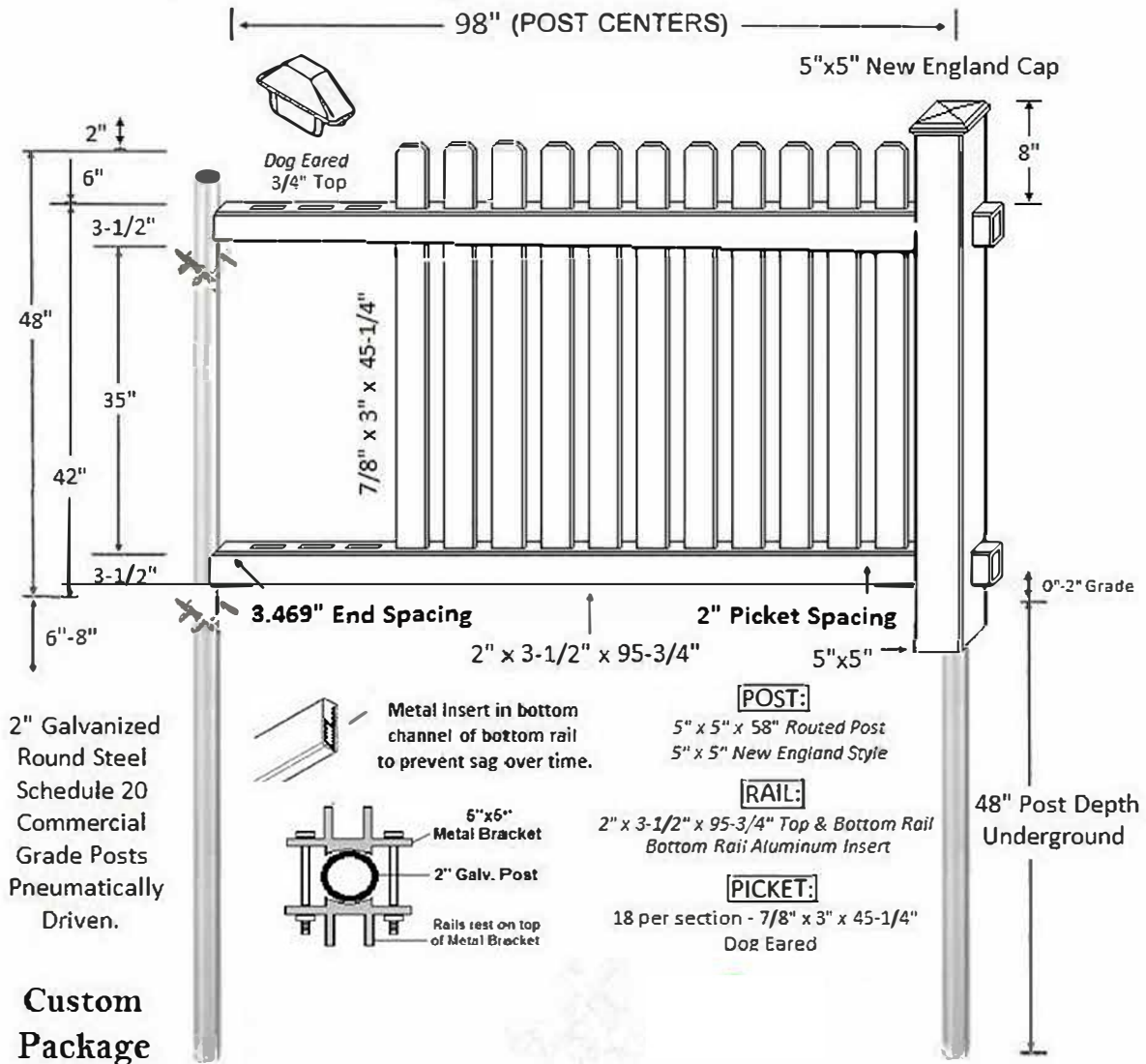



= Madison

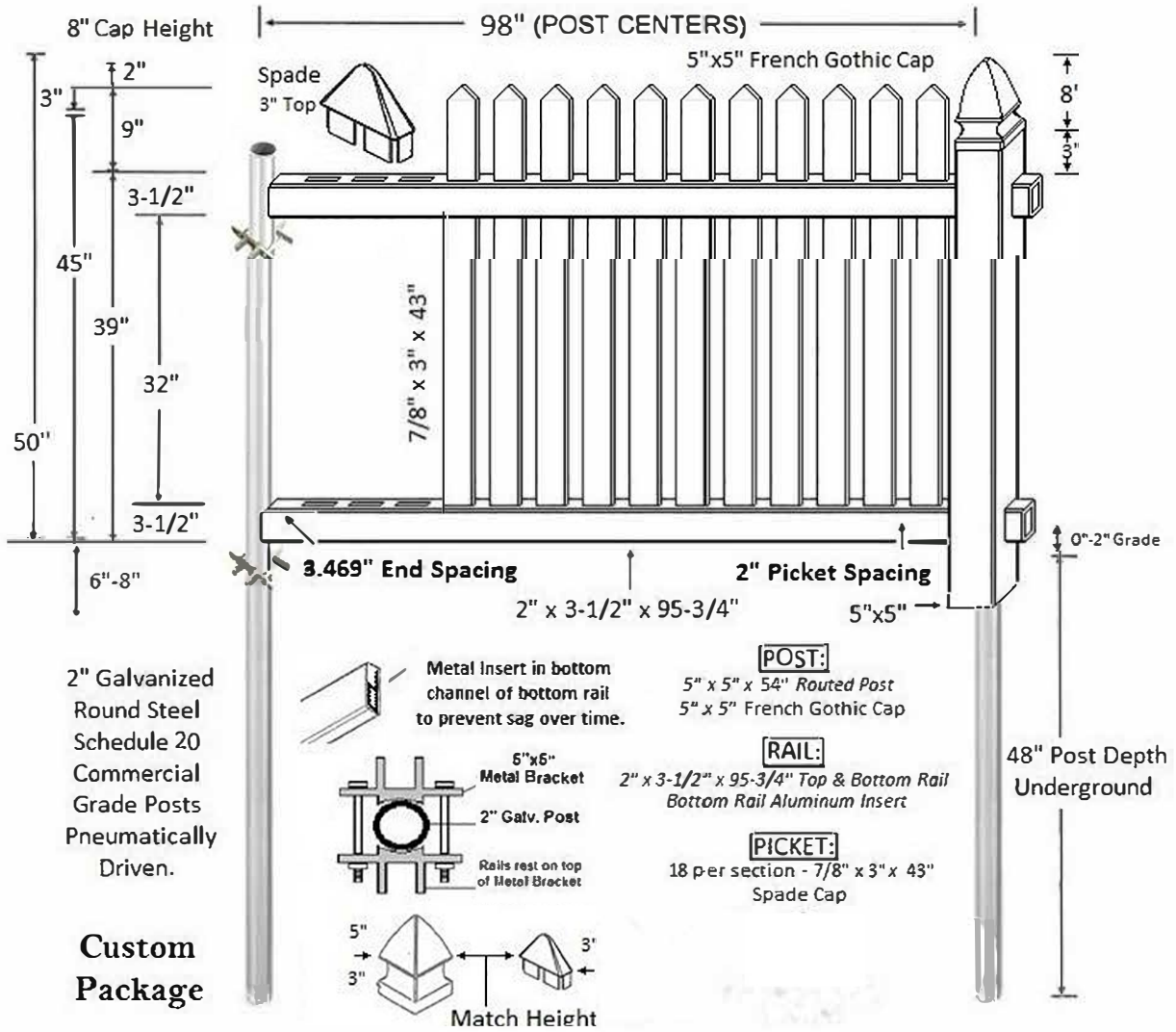

= Columbia Picket

(Exhibit E-7 type 1 picket) PVC
 4' Tall 2" Spaced 3" Picket Spade



 LEADING EDGE FENCES, LLC = Franklin

 ACTION FENCE = Cambridge Picket

(Exhibit E-6 type 1 stick) PVC
 4' Tall 50/50 1.5" Spaced 1 3/8" Picket

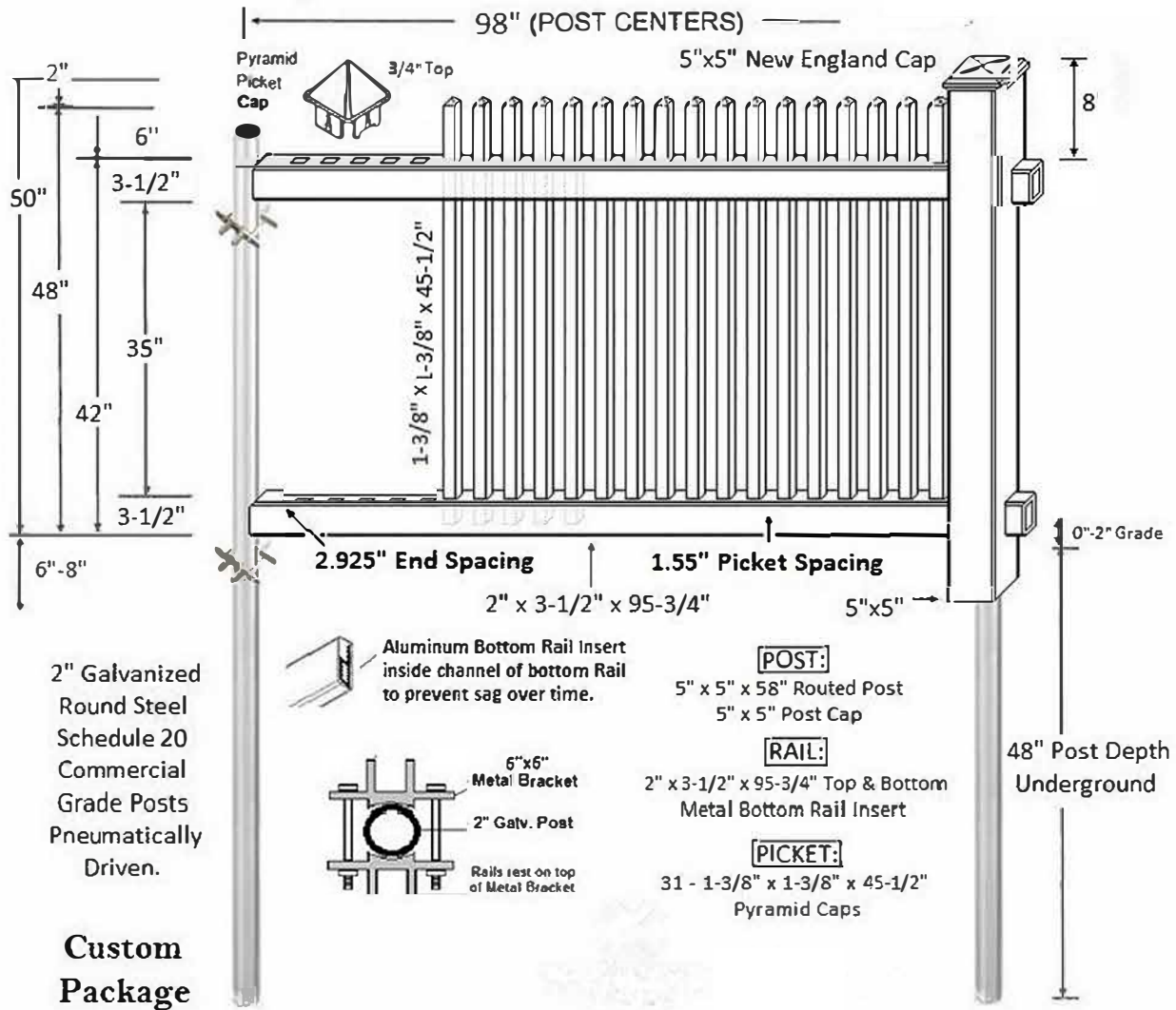



= Hamilton

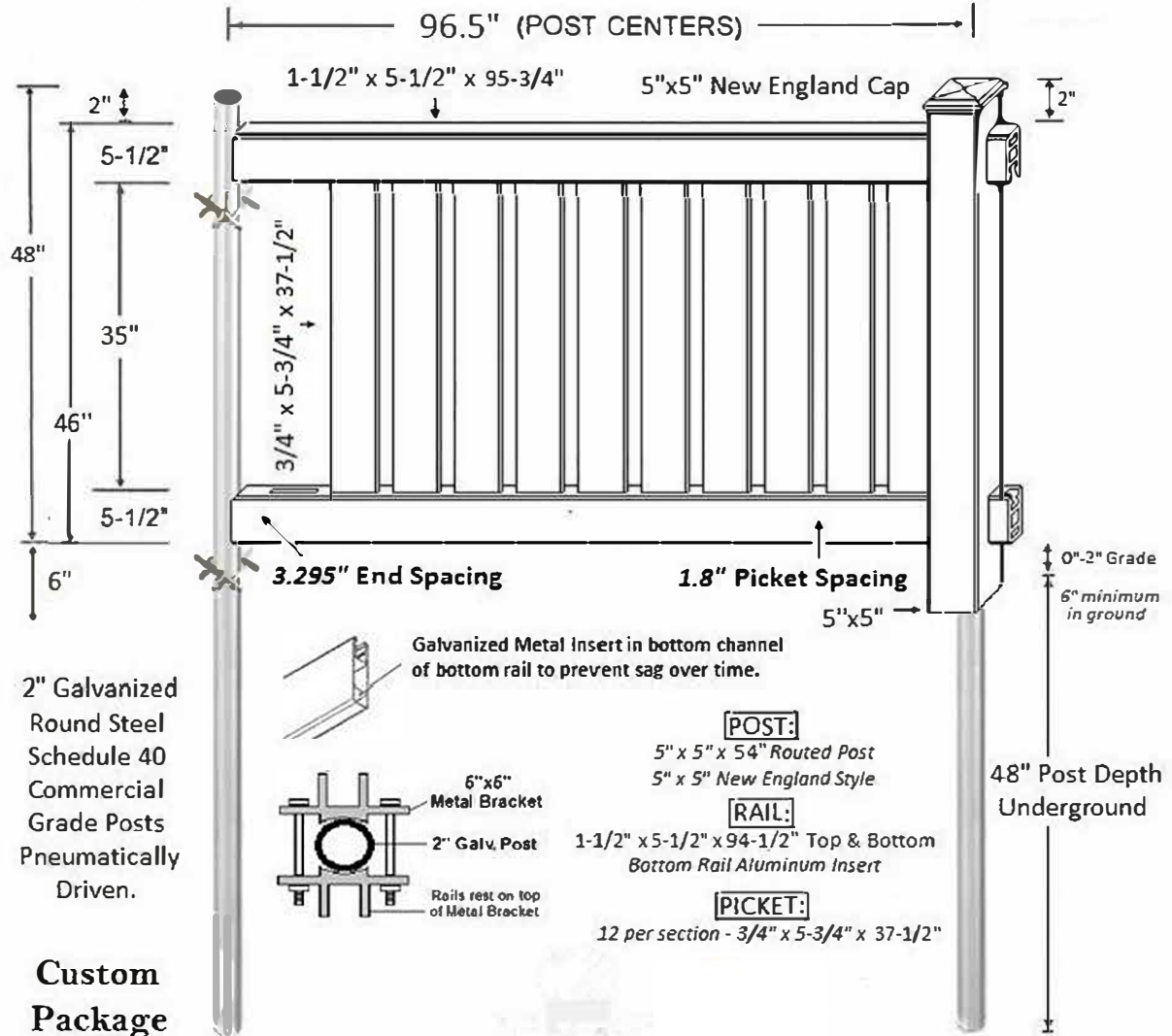

= Lexington

(Exhibit E) PVC
 4' Tall 2" Spaced 6" Wide Picket



 LEADING EDGE FENCES, LLC = Washington

 ACTION FENCE = Jackson

(Exhibit E-4)
4' Tall Solid Prairie Style

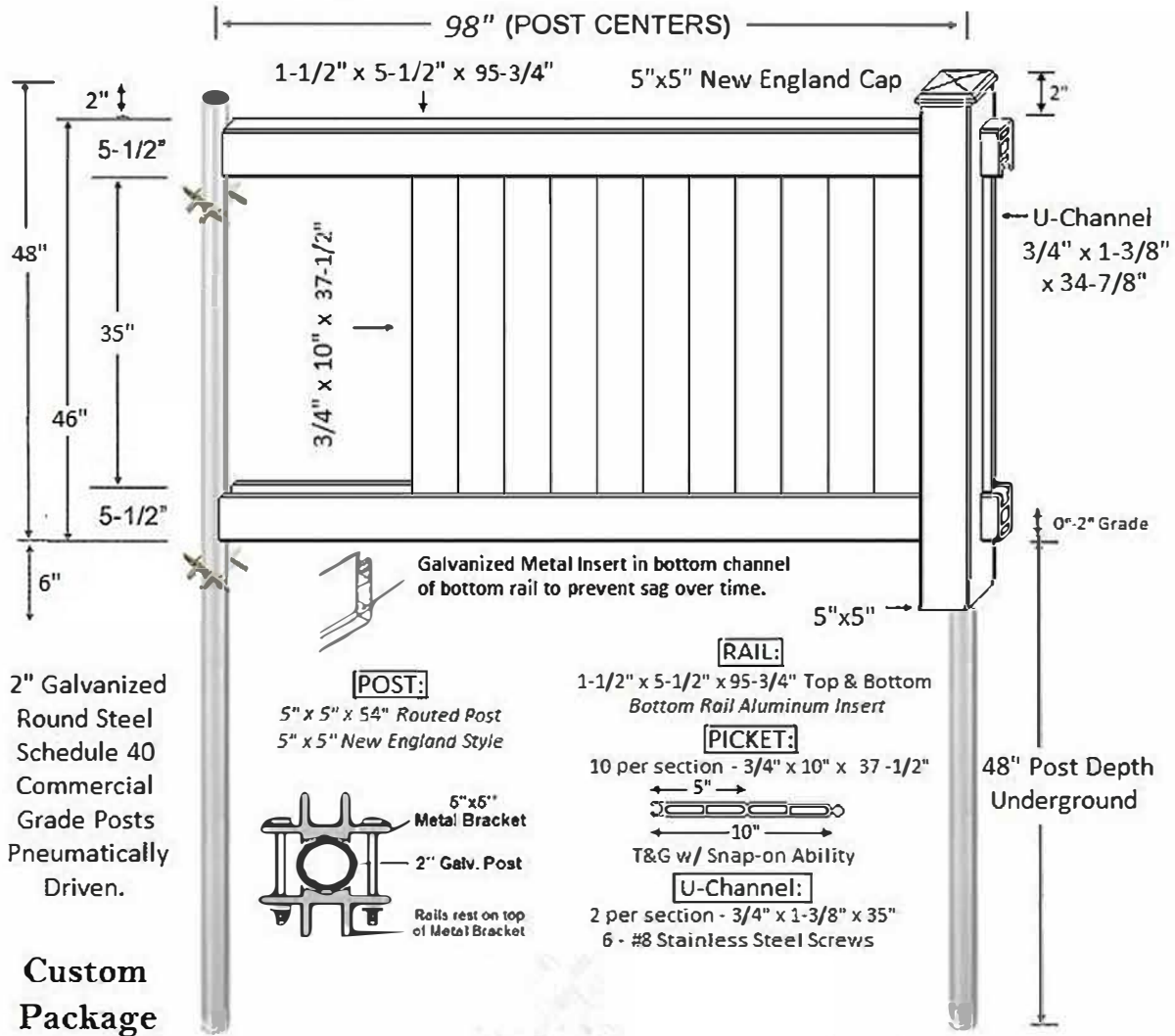

= Middleton



= Cambridge

(Exhibit E-8 type 1 rail) PVC
 4' Tall 50/50 1.5" Spaced 1 3/8" Picket

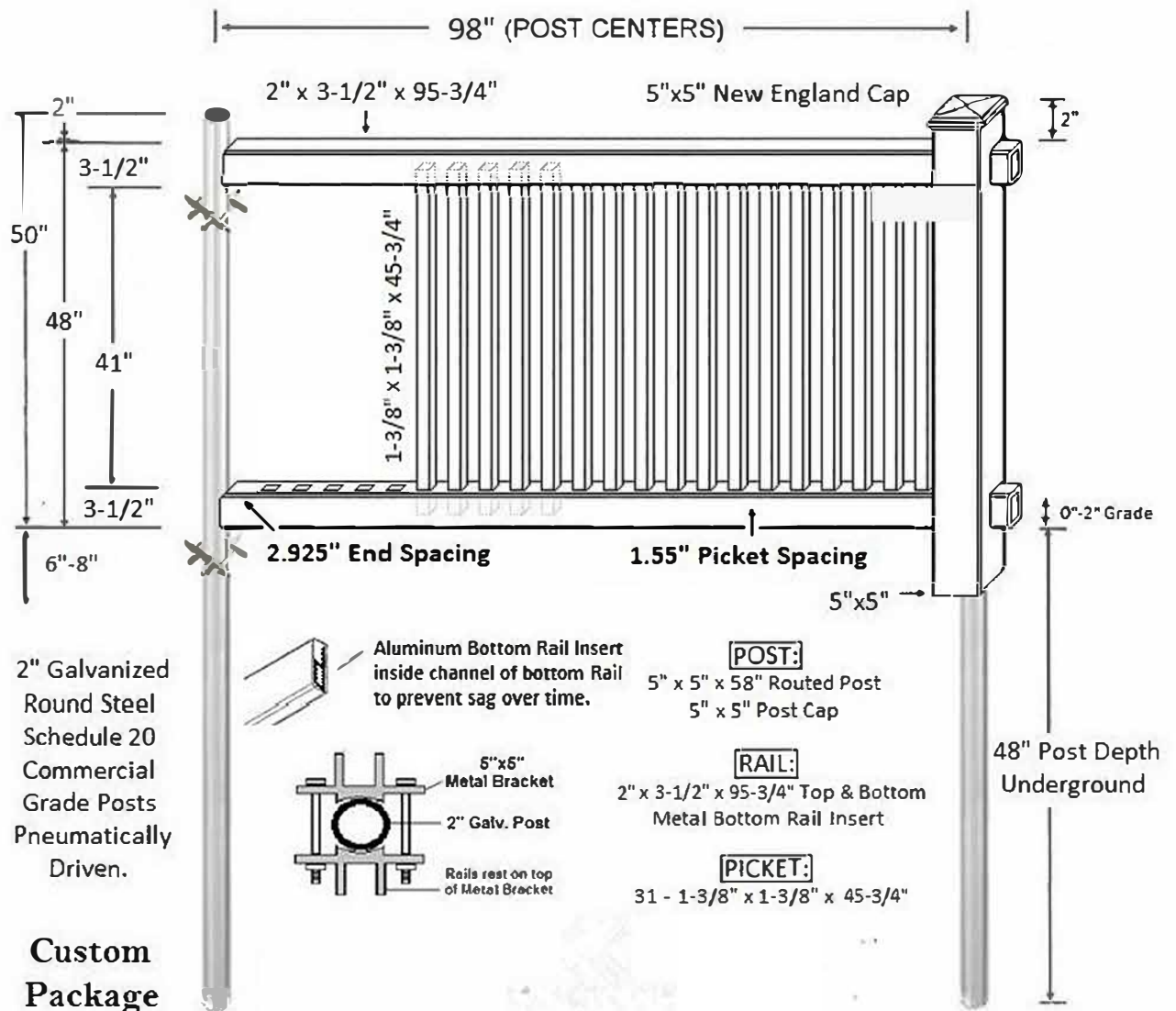

 LEADING EDGE FENCES, LLC = Henry

 ACTION FENCE = Not Available

(Exhibit E-3 type 2 board) PVC
 5' Tall 3 Rail 2" Spaced 3" Picket

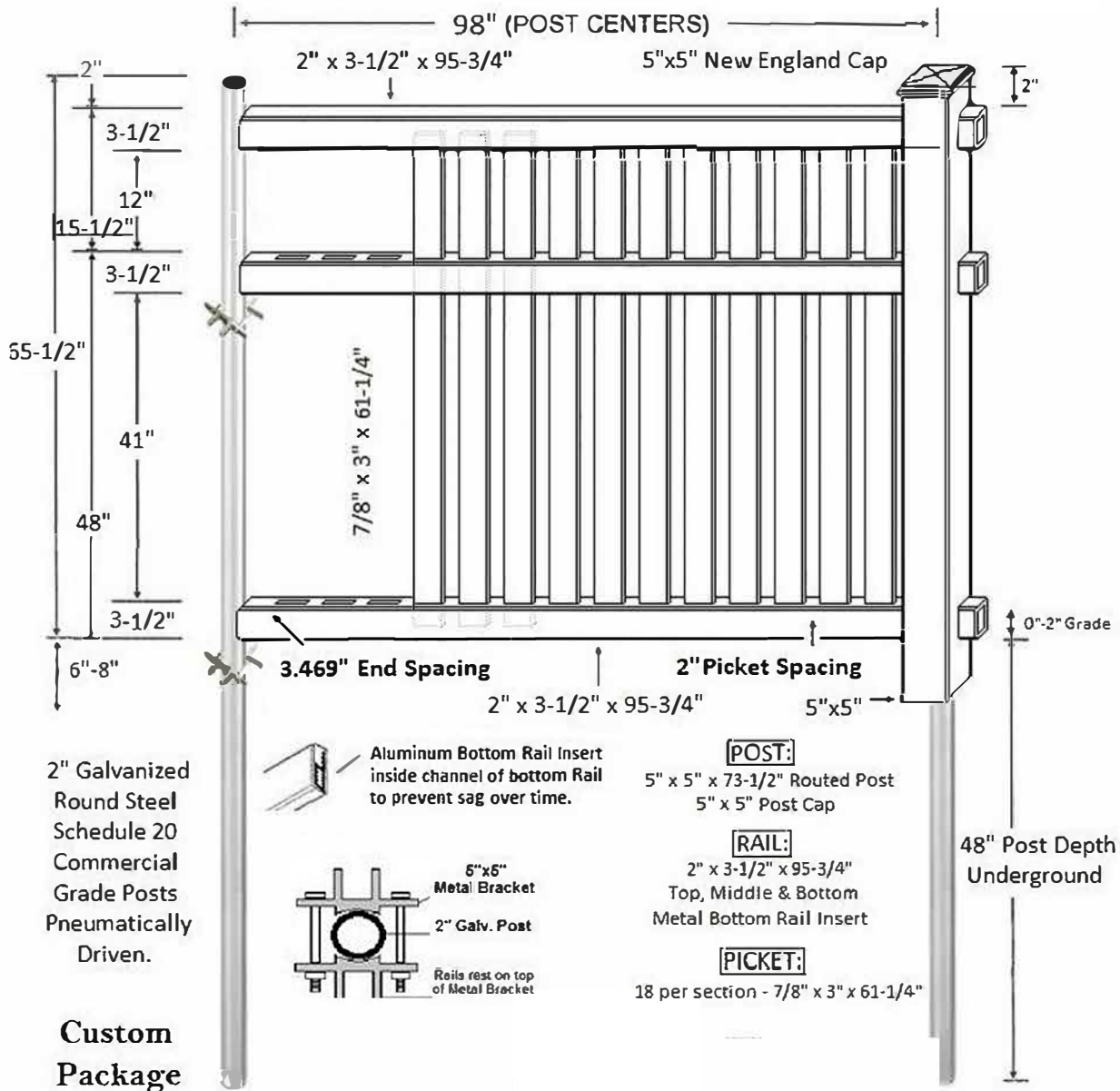

= John Adams



= Fairhaven

(Exhibit E-3 type 2 Rail) PVC
 5' Tall 3 Rail 1.5" Spaced 1-3/8" Picket

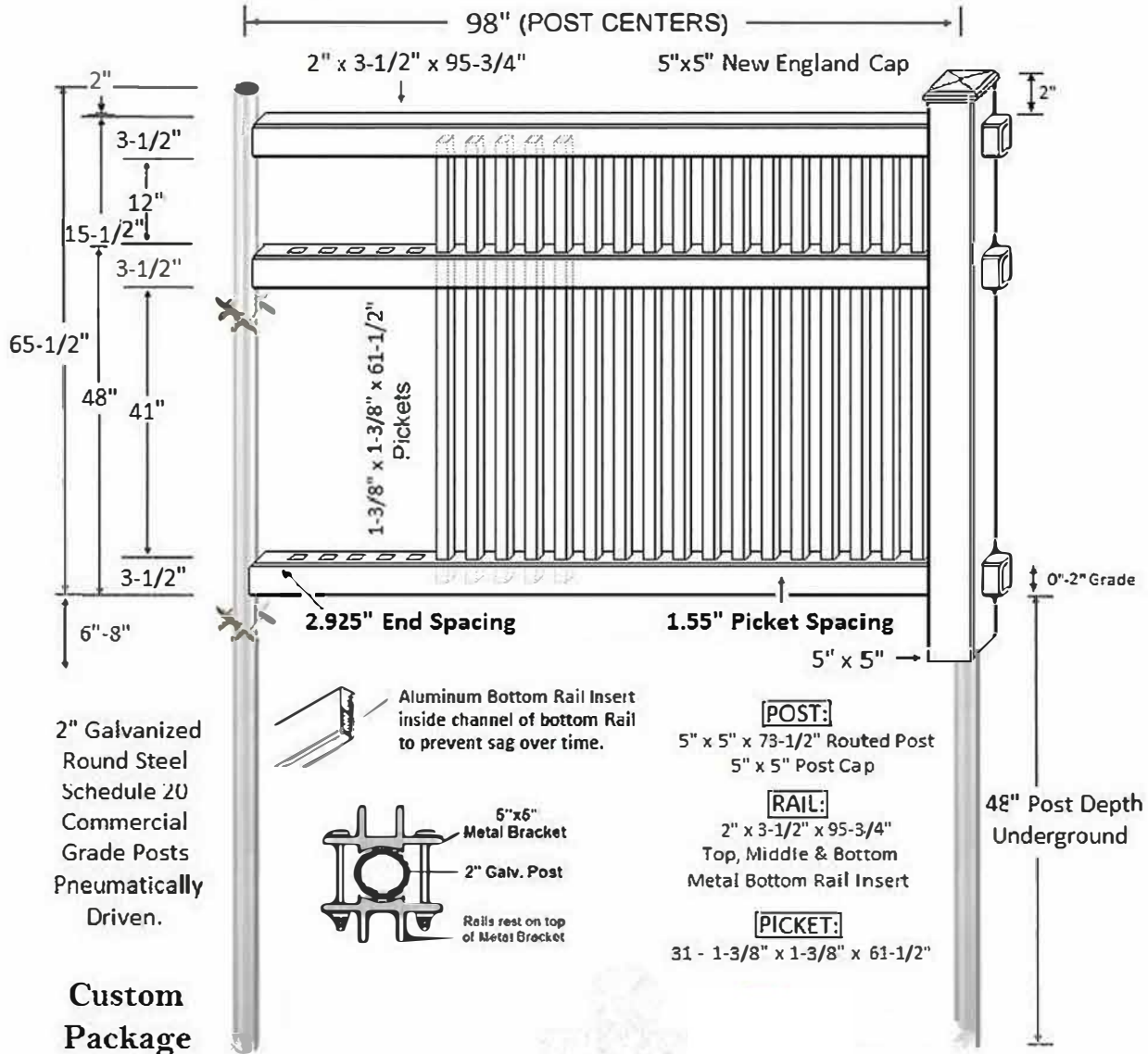

= Samuel Adams



= Fairfield

Exhibit E-3 Type II Picket

5' Tall 3 rail 1.5" Spaced 1-3/8" Picket
w/ ladder lattice on top

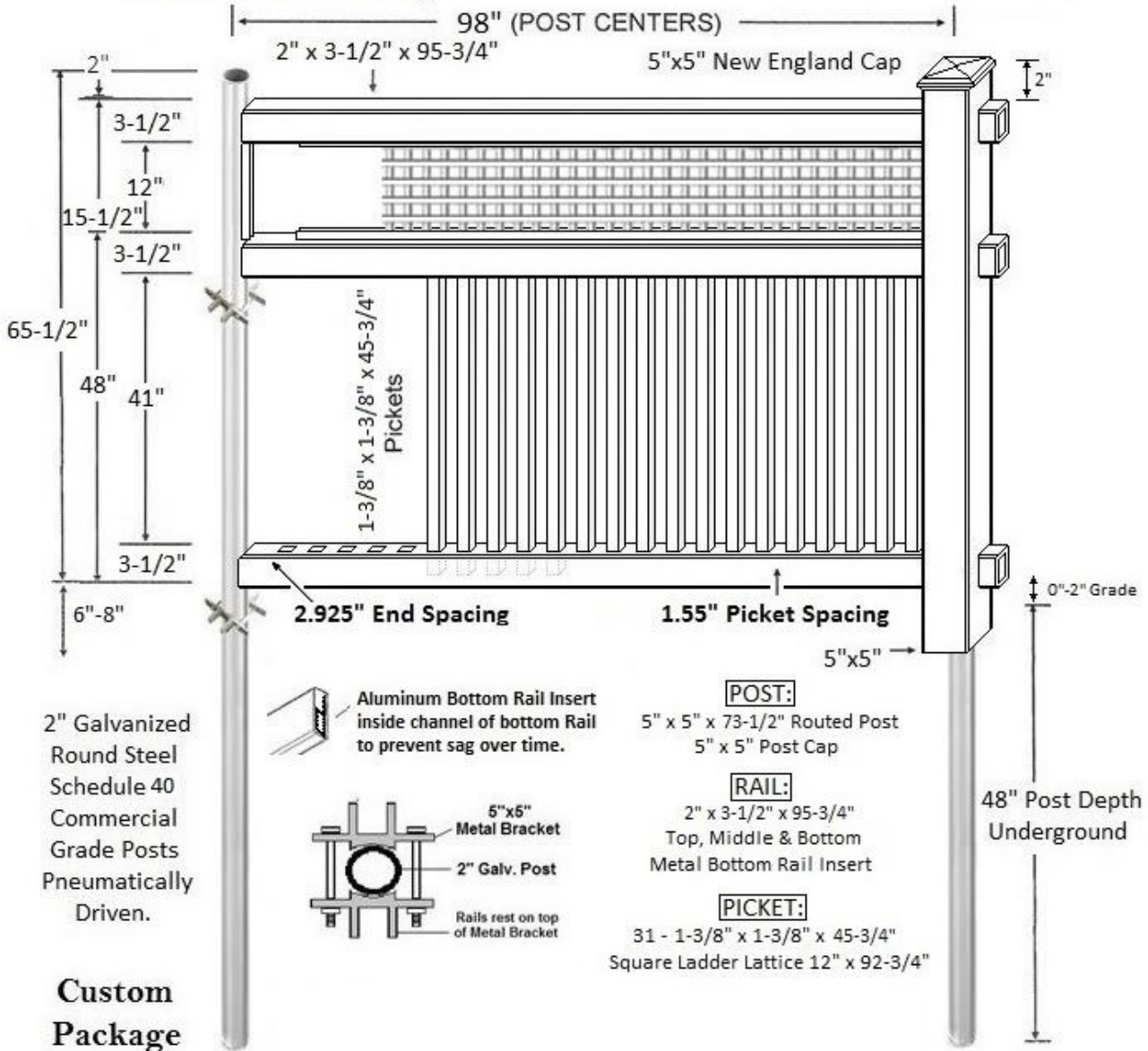

= Mason



= Not Available

(Exhibit E-3 type 2 stick) PVC
 5' Tall 3 rail 1.5" Spaced 1-3/8" Picket
 w/ diagonal lattice on top

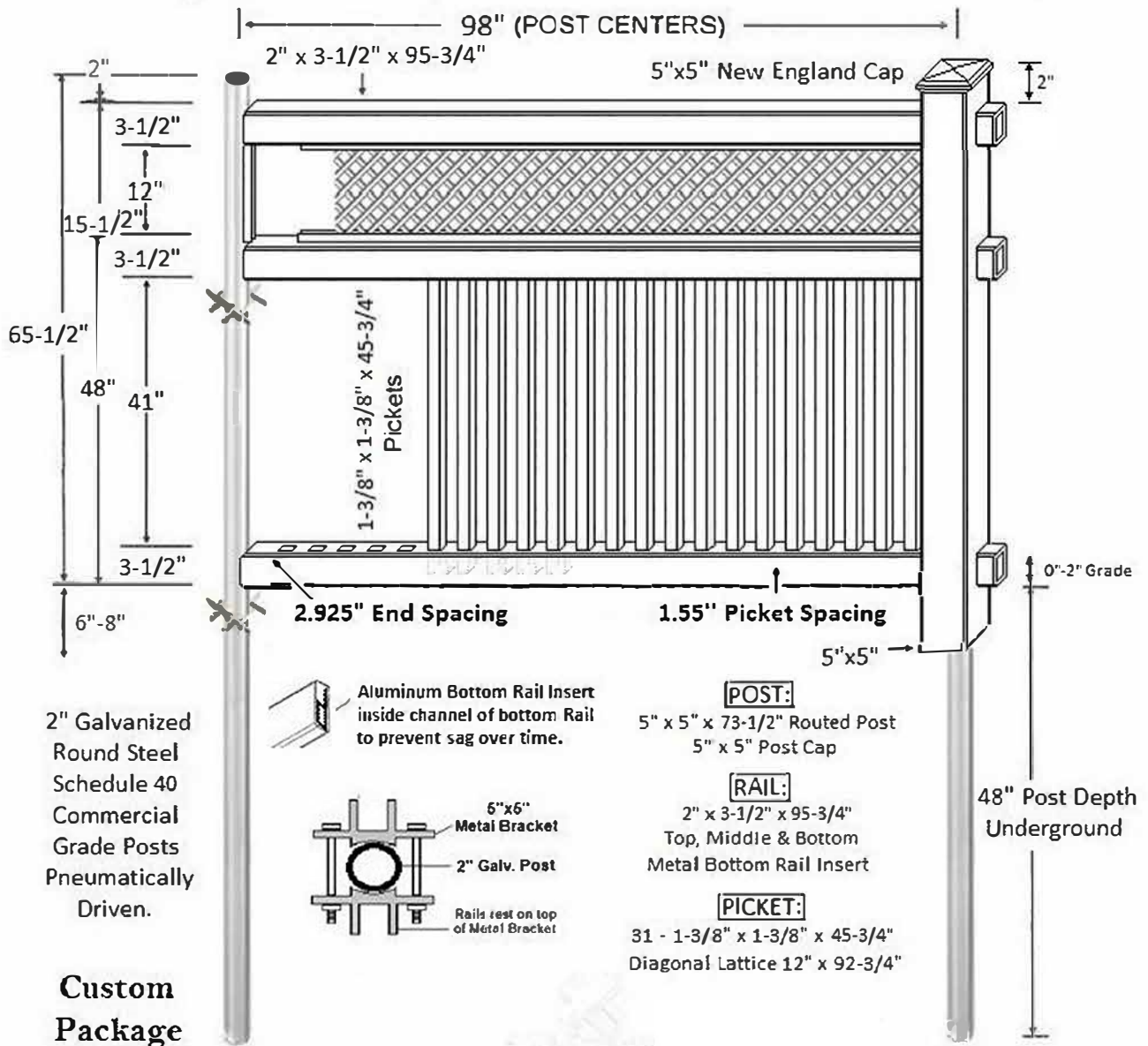

Custom Package



= Marshall



= Not Available

Exhibit E w/ Lattice

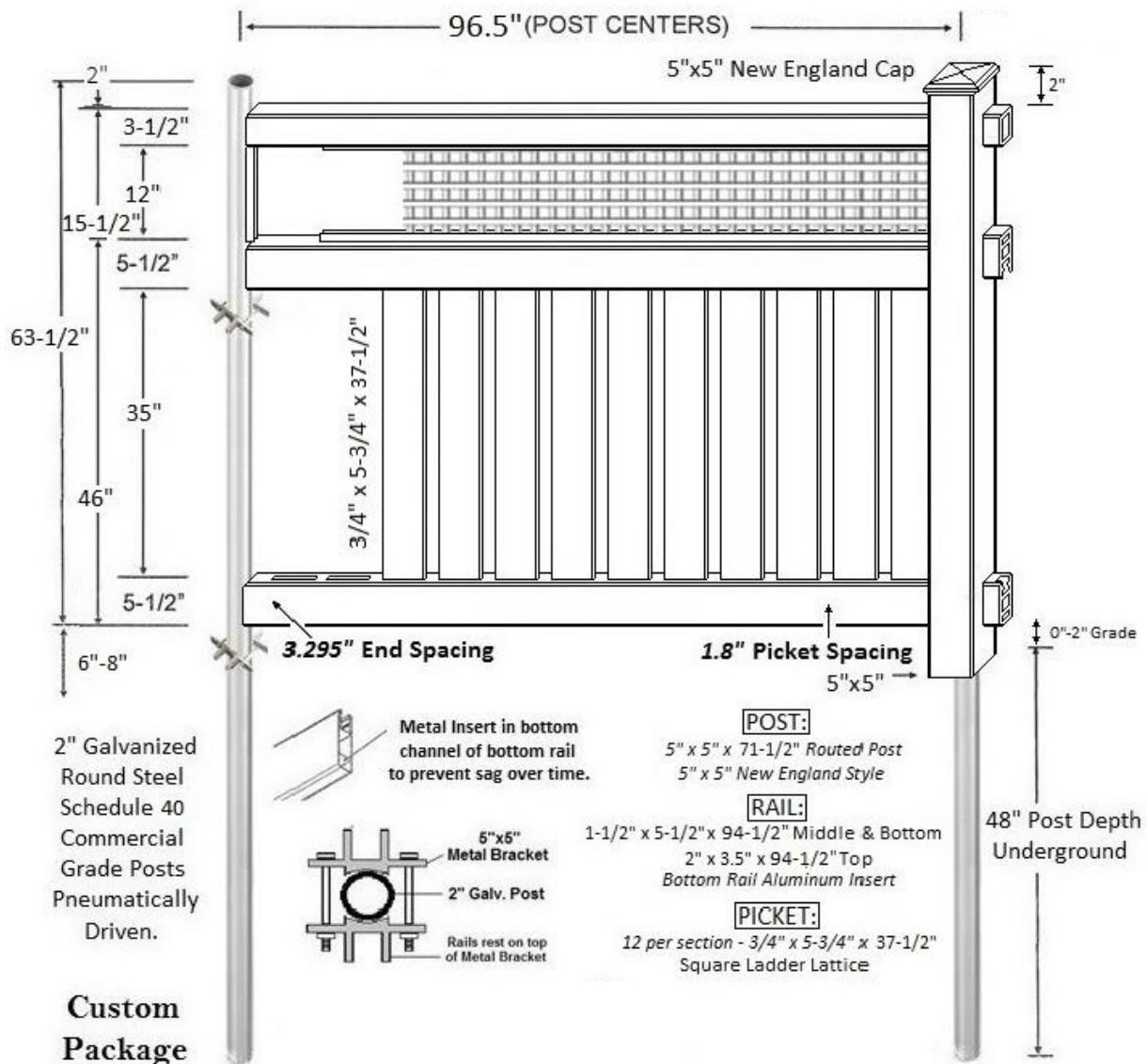

= Abigail



= Jackson With Lattice

Everguard Regency (4' Height Only)

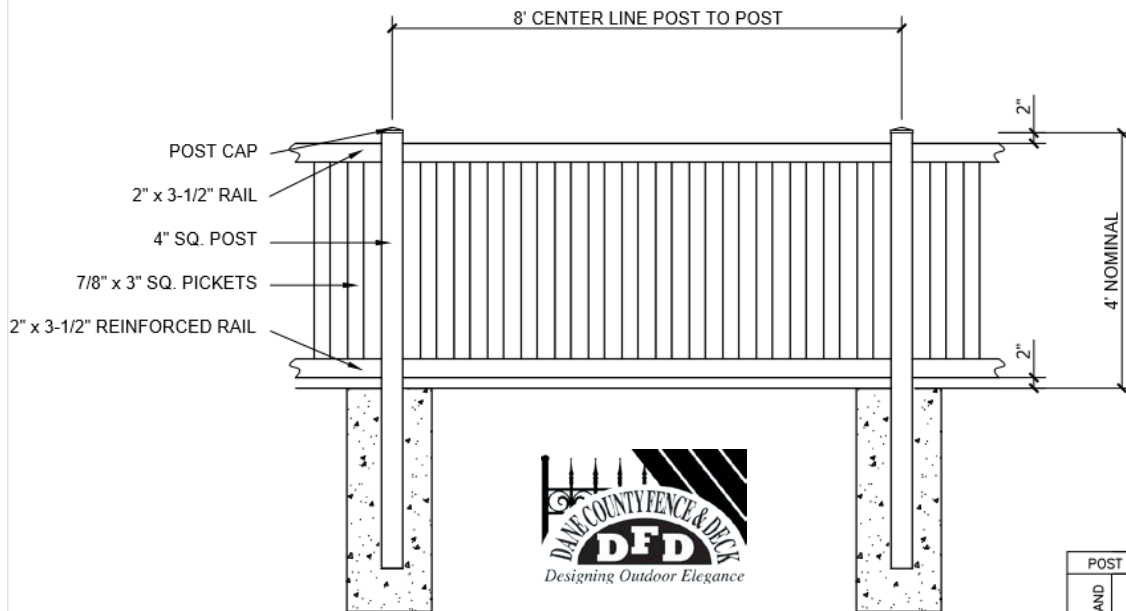
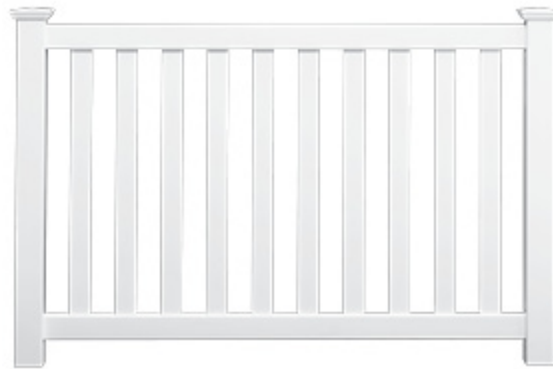

POST CAP OPTIONS			
NEW ENGLAND	GOthic	INSIDE PYRAMID	OUTSIDE PYRAMID

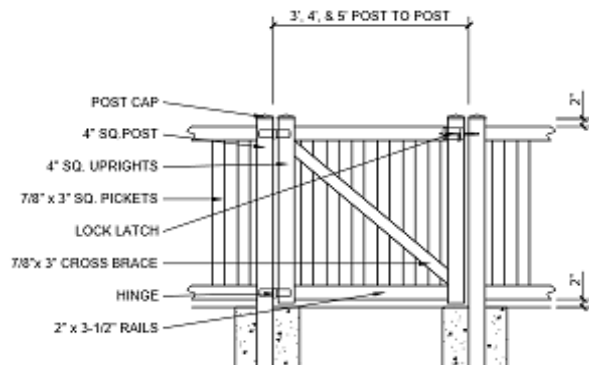

Everguard Estate Privacy (4' Height Only)

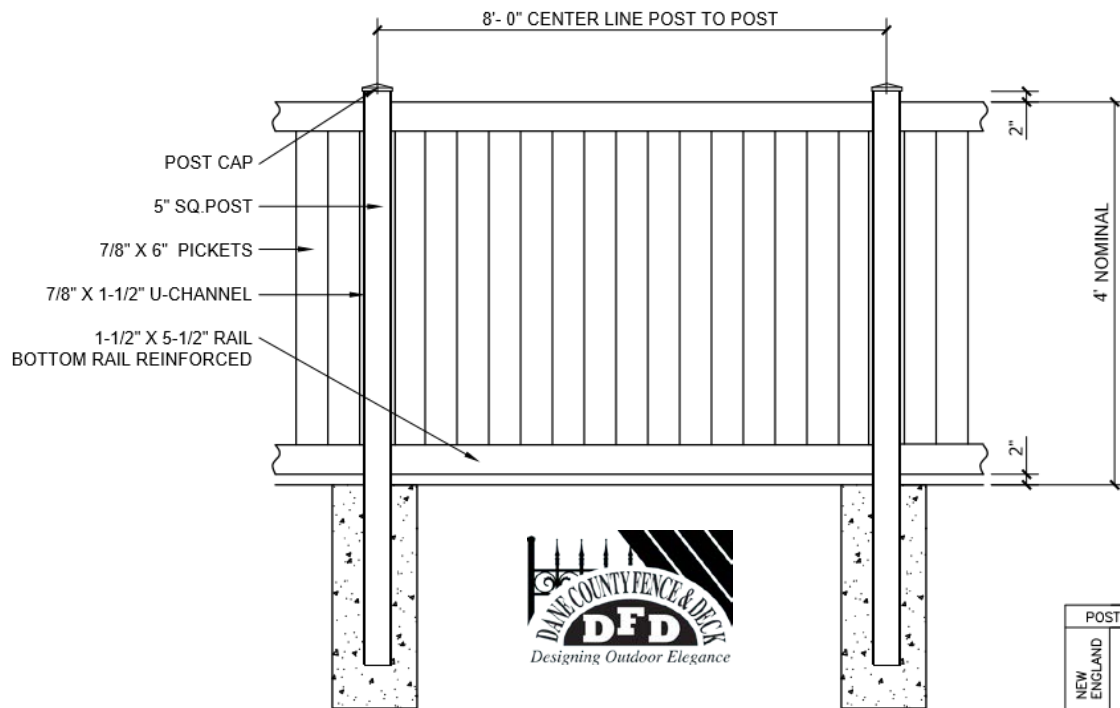
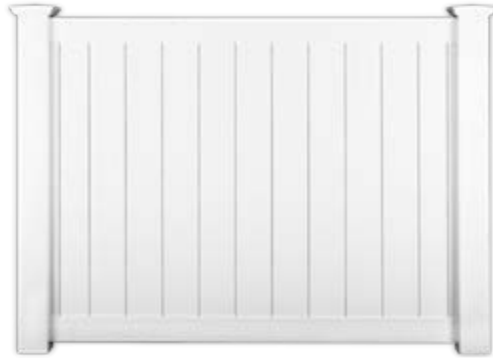

POST CAP OPTIONS			
NEW ENGLAND	GOthic	INSIDE PYRAMID	OUTSIDE PYRAMID

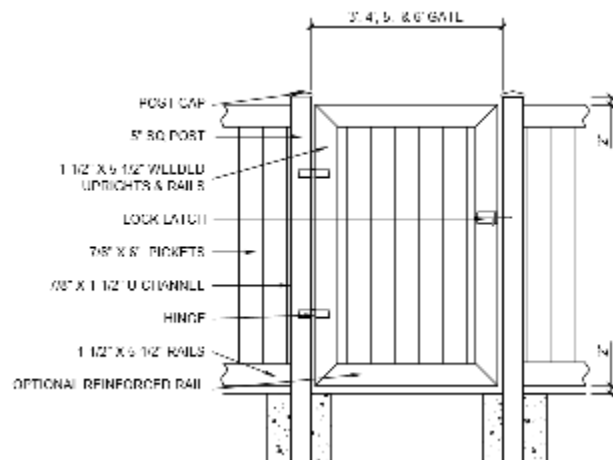

Everguard Camden (4' Height Only)

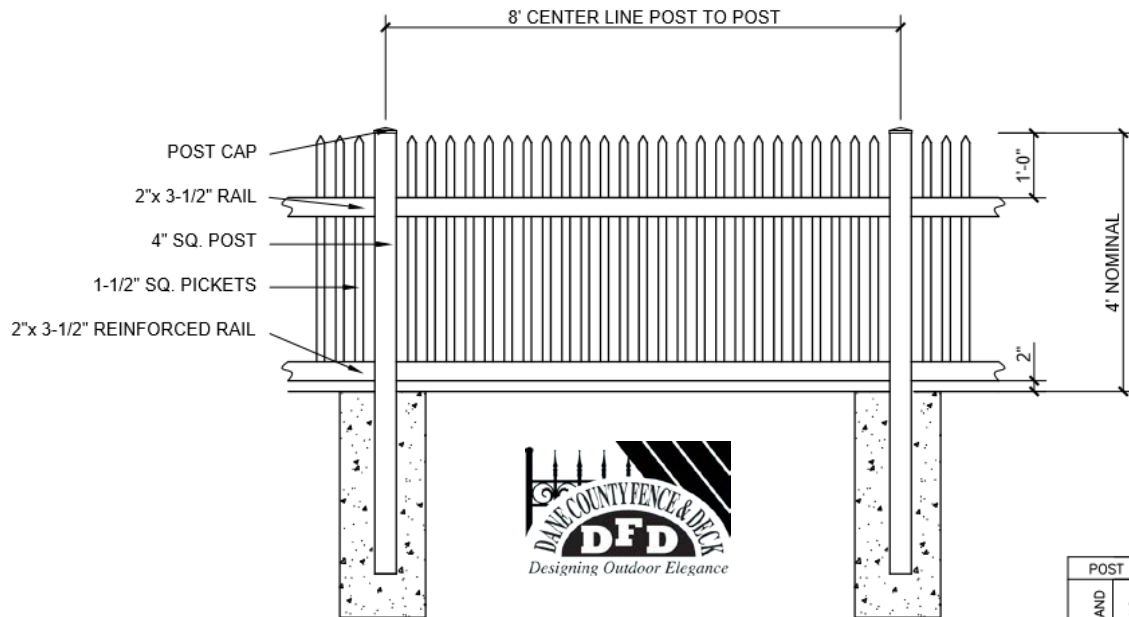
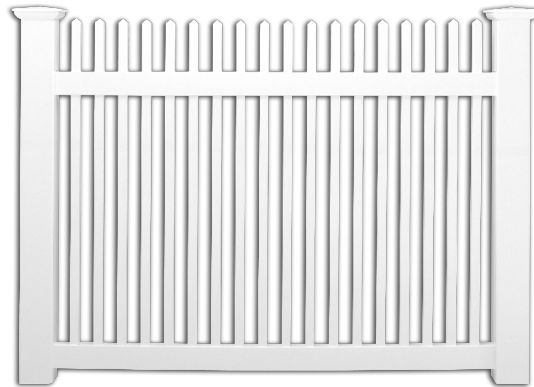

POST CAP OPTIONS			
NEW ENGLAND	GOTHIC	INSIDE PYRAMID	OUTSIDE PYRAMID

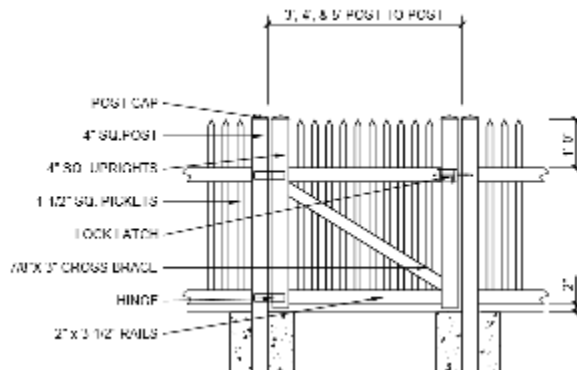

Everguard Savannah (4' Height Only)

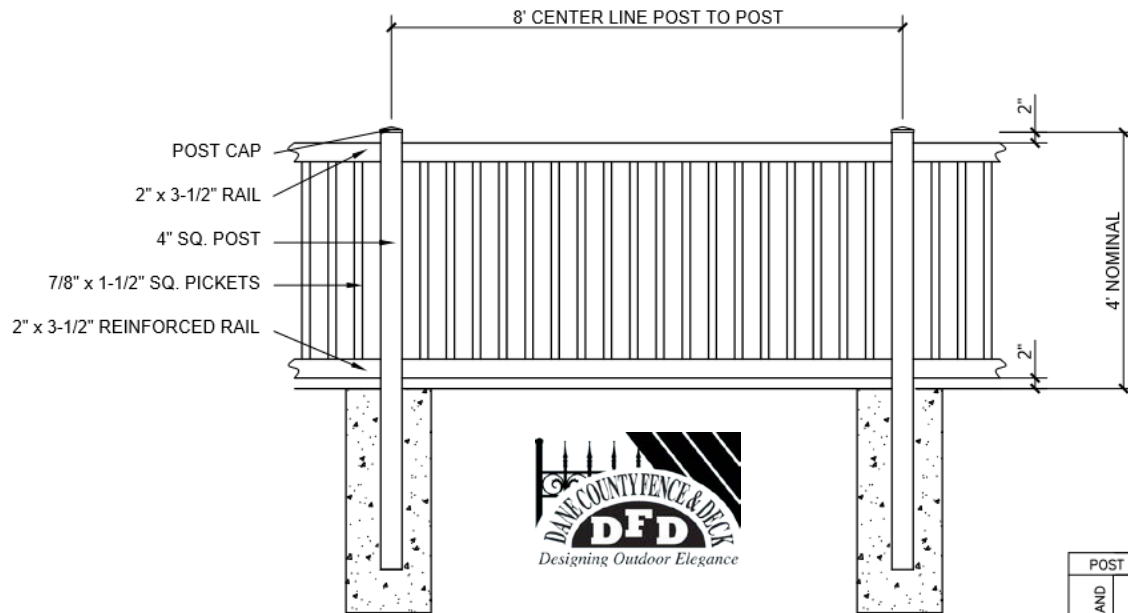
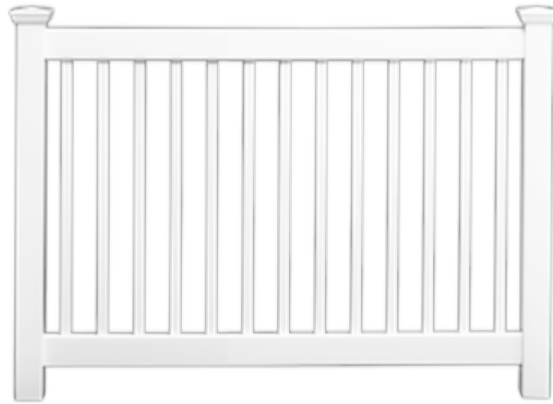

POST CAP OPTIONS			
NEW ENGLAND	GOthic	INSIDE PYRAMID	OUTSIDE PYRAMID

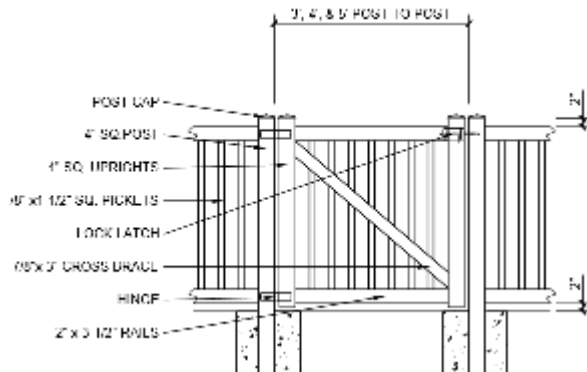

Everguard Melrose (4' Height Only)

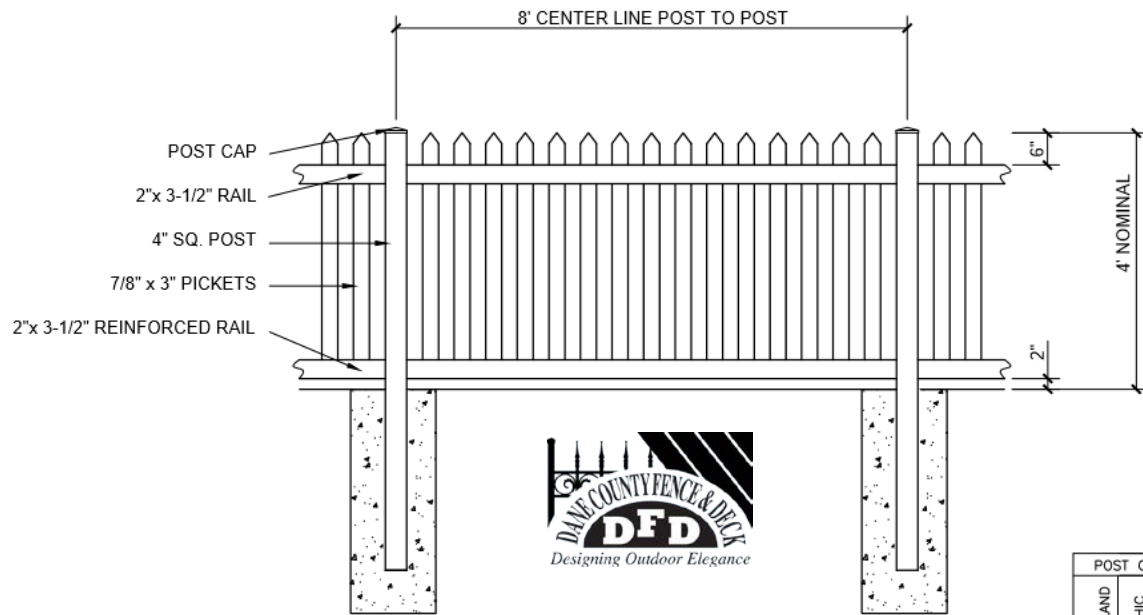
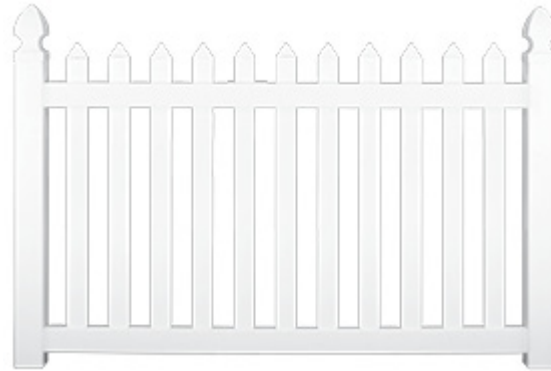

POST CAP OPTIONS			
NEW ENGLAND	GOthic	INSIDE PYRAMID	OUTSIDE PYRAMID

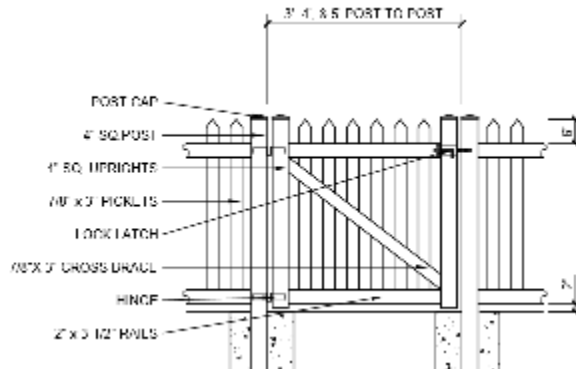

Everguard Barrington (5' Height Only)

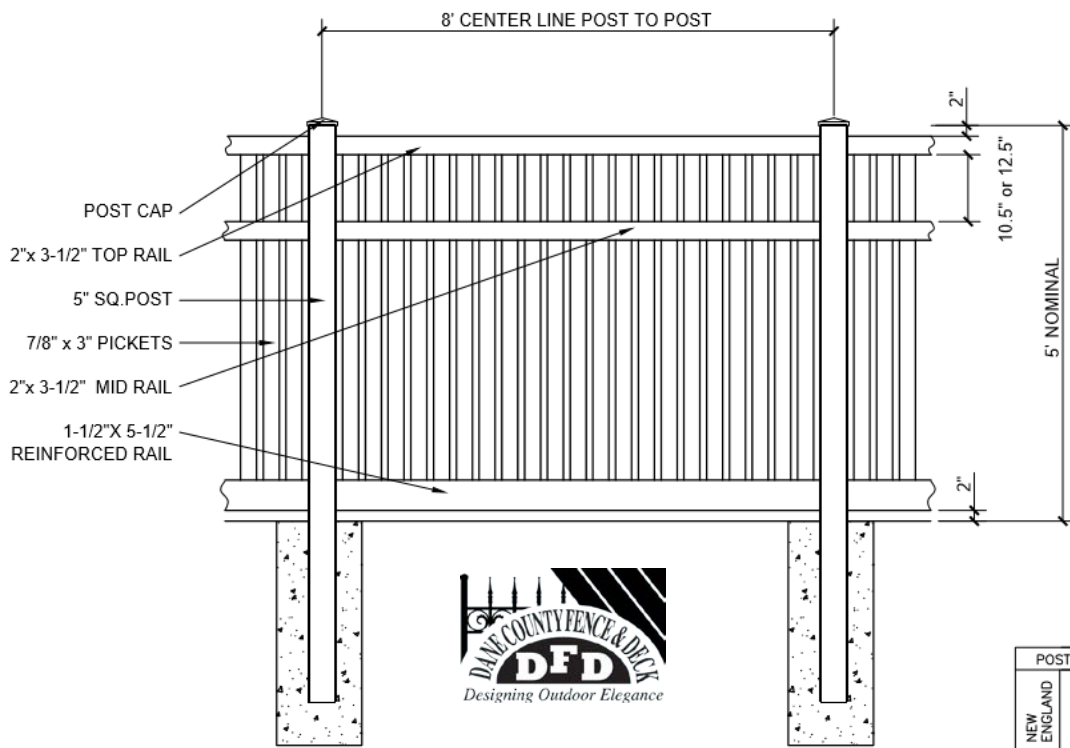

POST CAP OPTIONS			
NEW ENGLAND	GOthic	INSIDE PYRAMID	OUTSIDE PYRAMID

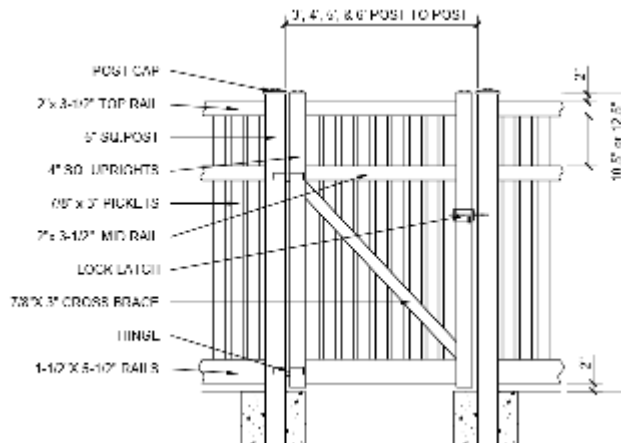

Everguard Estate Lattice (5' Height Only)

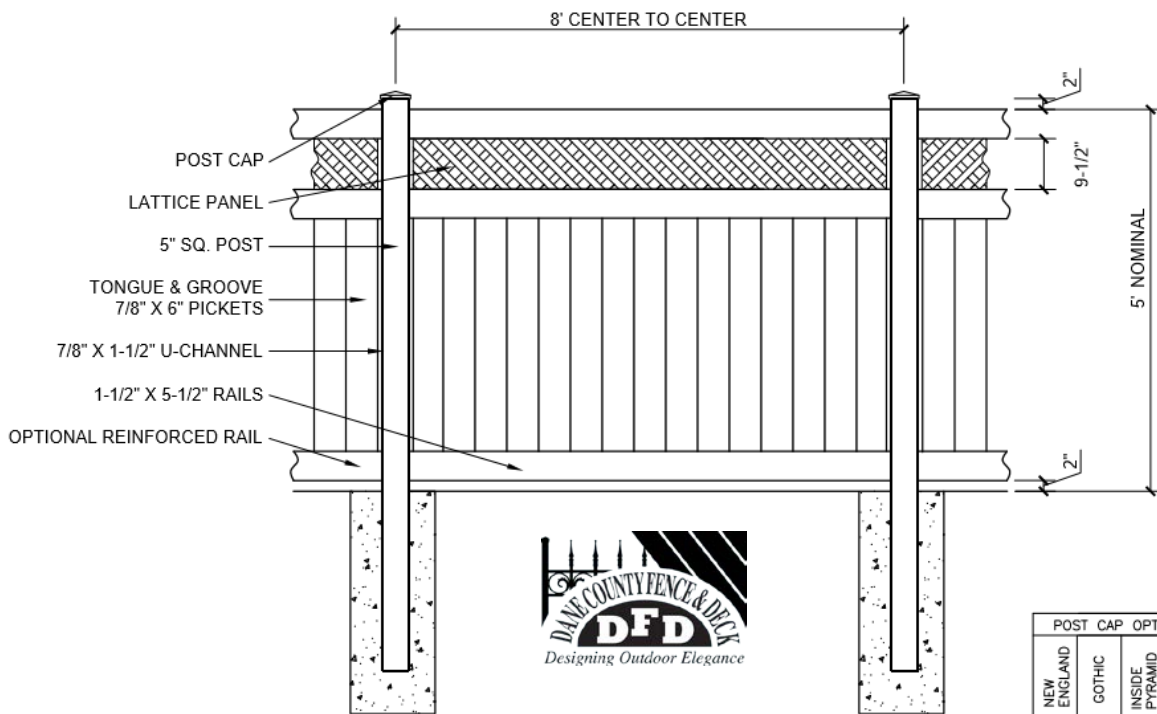

POST CAP OPTIONS			
NEW ENGLAND	GOthic	INSIDE PYRAMID	OUTSIDE PYRAMID

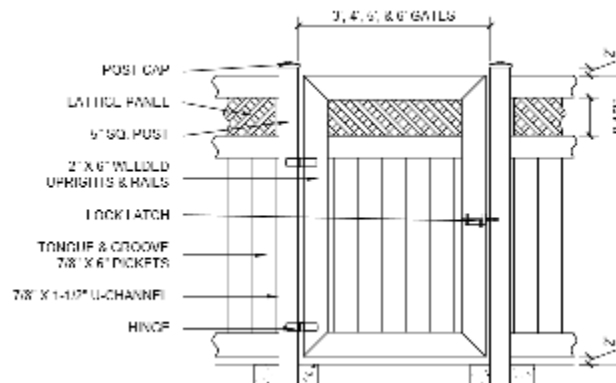

Everguard Hampton (5' Height Only)

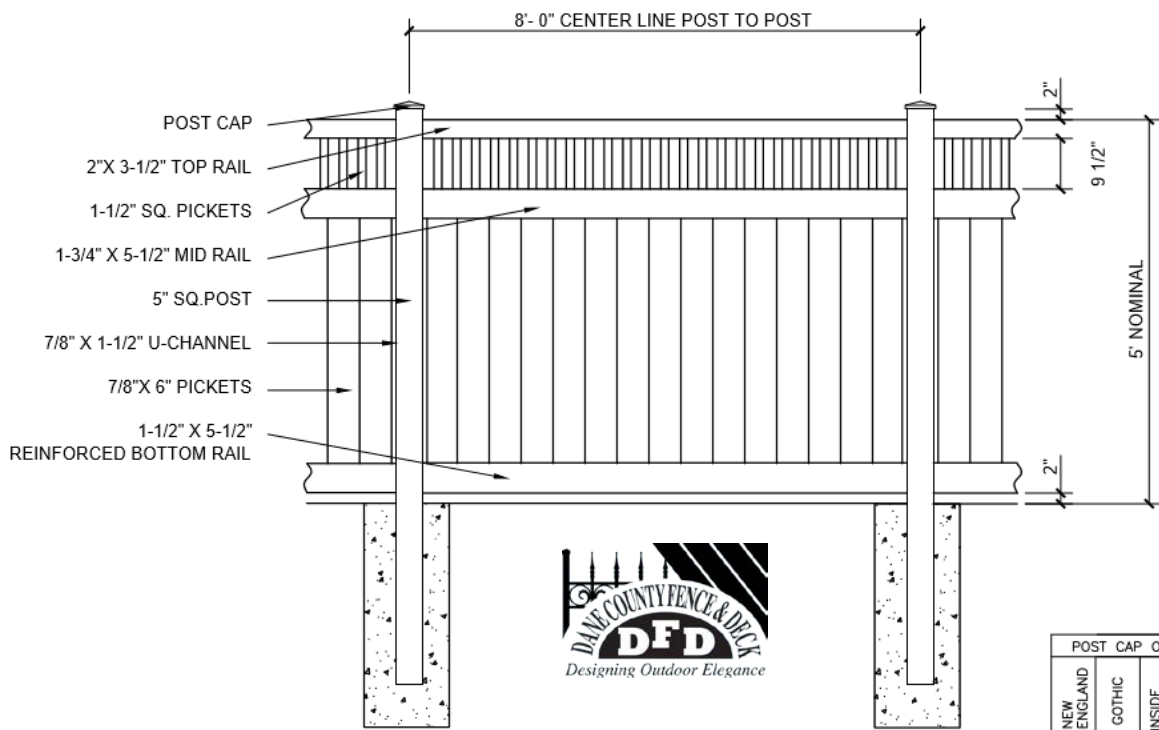

POST CAP OPTIONS			
NEW ENGLAND	GOTHIC	INSIDE PYRAMID	OUTSIDE PYRAMID

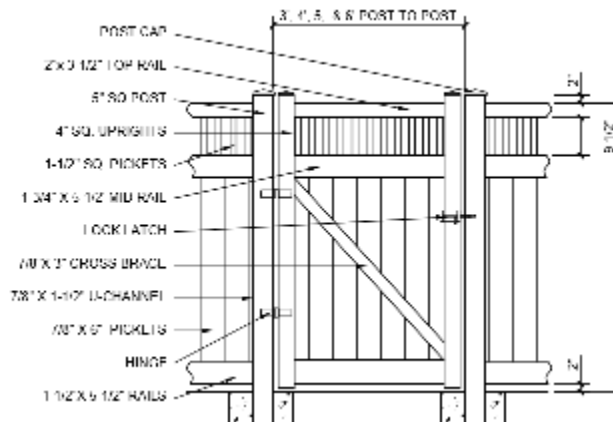
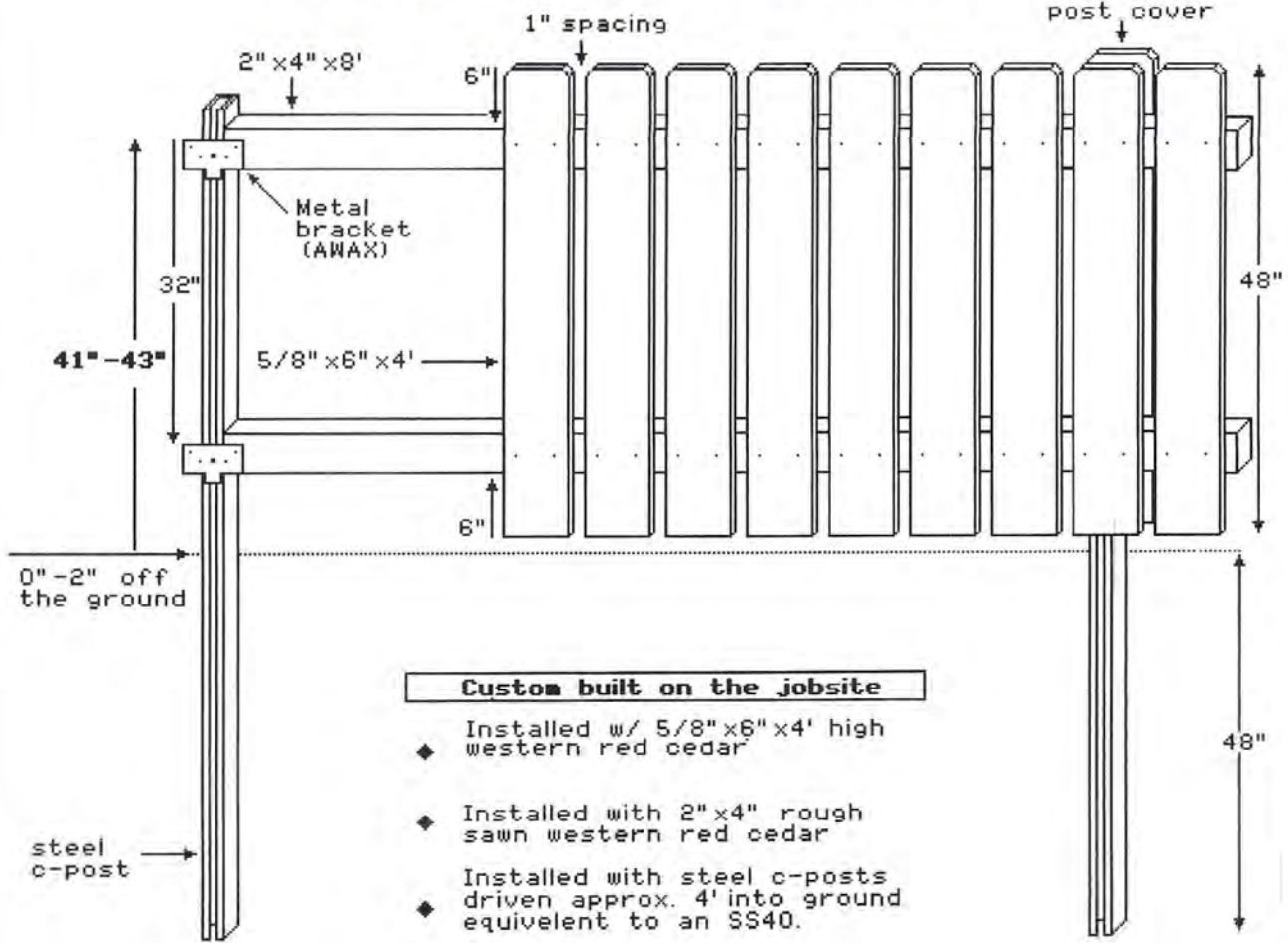

EXHIBIT E-1

4' HIGH 1" SPACED 1" X 6" DOG-EARED FENCE USING WESTERN RED CEDAR



Custom built on the jobsite

- ◆ Installed w/ 5/8" x 6" x 4' high western red cedar
- ◆ Installed with 2" x 4" rough sawn western red cedar
- ◆ Installed with steel c-posts driven approx. 4' into ground equivalent to an SS40.
- ◆ Installed with metal brackets (awax) that attach to post and screw into stringers
- ◆ Decorative Maxima hinges and lockable Maxima latches

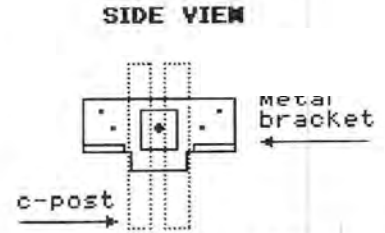
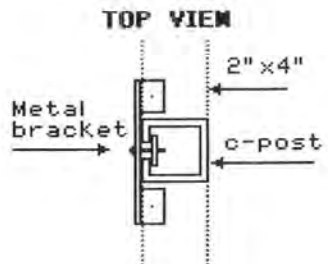
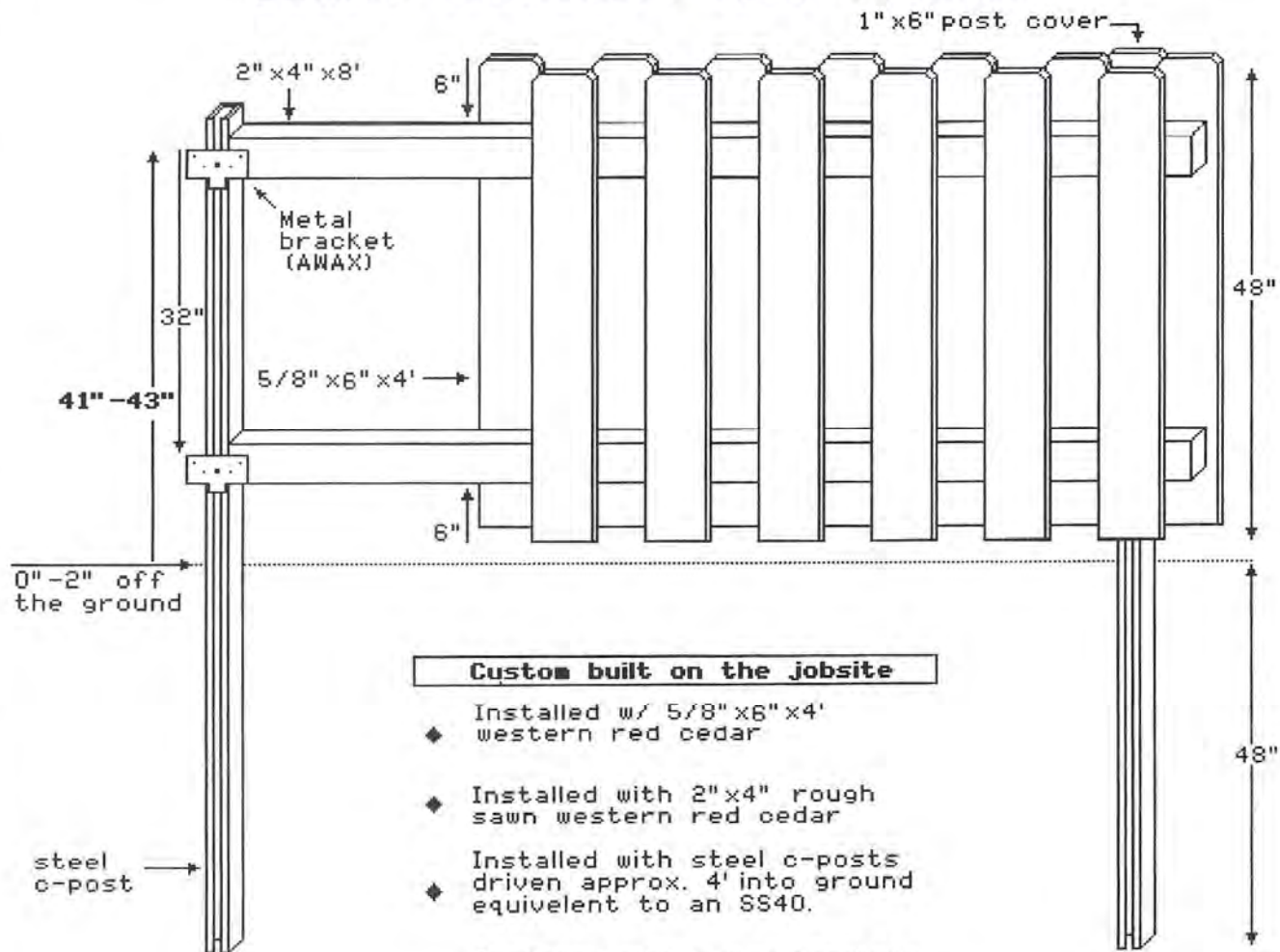

EXHIBIT E-2

4' HIGH WOOD BOARD ON BOARD DOG-EARED USING WESTERN RED CEDAR



Custom built on the jobsite

- ◆ Installed w/ 5/8" x 6" x 4' western red cedar
- ◆ Installed with 2" x 4" rough sawn western red cedar
- ◆ Installed with steel c-posts driven approx. 4' into ground equivalent to an SS40.
- ◆ Installed with metal brackets (awax) that attach to post and screw into stringers
- ◆ Decorative Maxima hinges and lockable Maxima latches

TOP VIEW

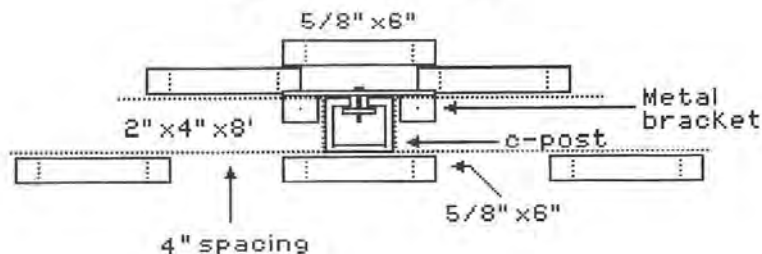

SIDE VIEW

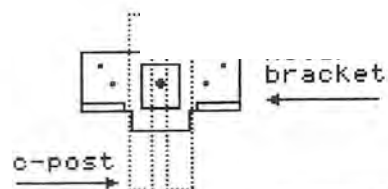
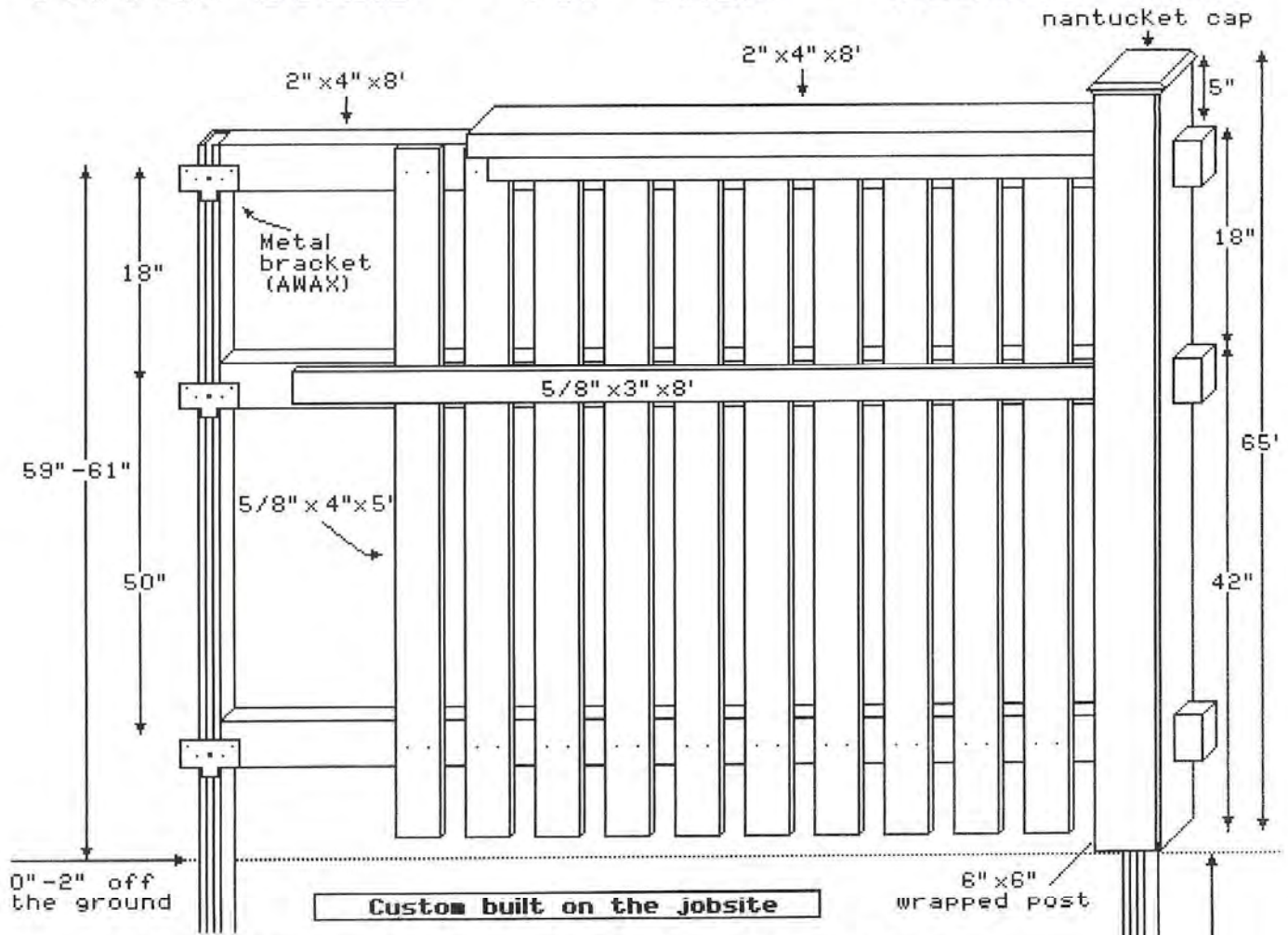

EXHIBIT E-3 / Type II Board

5' HIGH 1X4 PICKET WITH A 2" SPACE W/ WRAPPED POSTS AND NANTUCKET CAPS TOPPER BOARD - TOP TRIM - MIDDLE TRIM



◆ Installed w/ 5/8" x 4" x 5' 5/8" x 6" x 5' & 5/8" x 3" x 8' western red cedar.

◆ Installed with 2" x 4" rough sawn western red cedar

◆ Installed with steel c-posts driven approx. 4' into ground equivalent to an SS40.

◆ Installed with metal brackets (awax) that attach to post and screw into stringers

◆ Installed with decorative nantucket post caps to fit 6" x 6" wrapped posts.

TOP VIEW

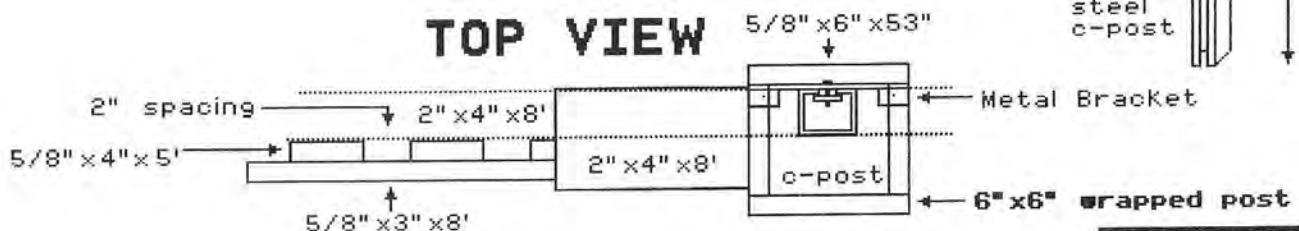

TYPE II BOARD

EXHIBIT E-3 / Type II Picket

5' HIGH 1X2 PICKET WITH A 2" SPACE W/ WRAPPED POSTS AND NANTUCKET CAPS TOPPER BOARD - TOP TRIM - MIDDLE TRIM SQUARE LATTICE

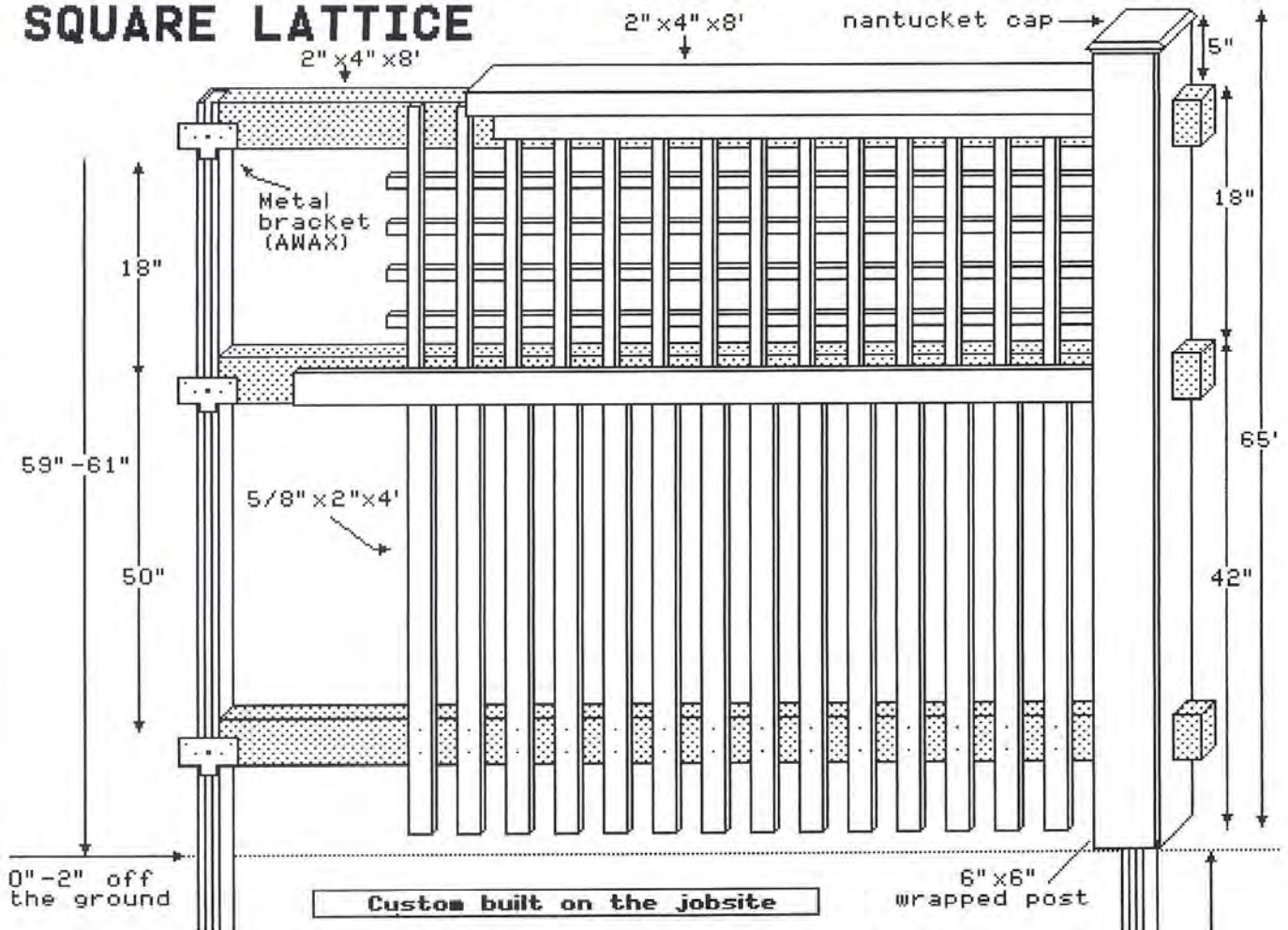

- ◆ Installed w/ 5/8" x 2" x 4' 5/8" x 6" x 5' & 5/8" x 3" x 8' western red cedar.
- ◆ Installed with 2" x 4" rough sawn western red cedar
- ◆ Installed with steel c-posts driven approx. 4' into ground equivalent to an SS40.

- ◆ Installed with metal brackets (awax) that attach to post and screw into stringers
- ◆ Installed with decorative nantucket post caps to fit 6" x 6" wrapped posts.
- ◆ Lattice will be 1" x 5/8" strips with 2 3/4" squares.

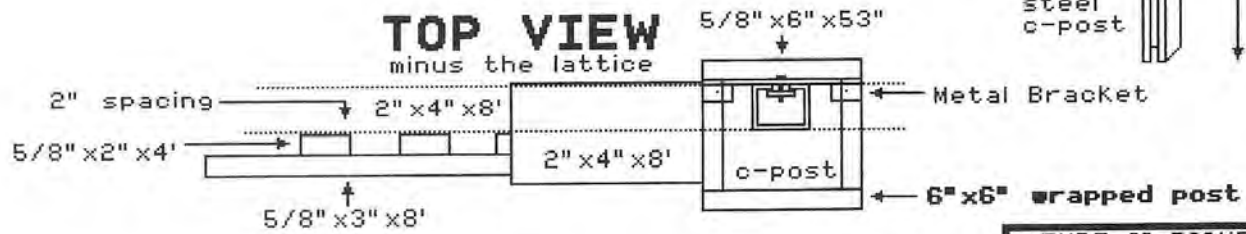

TYPE II PICKET

EXHIBIT E-3 / Type II Rail

5' HIGH 1X2 PICKET WITH A 2" SPACE W/ WRAPPED POSTS AND NANTUCKET CAPS TOPPER BOARD - TOP TRIM - MIDDLE TRIM

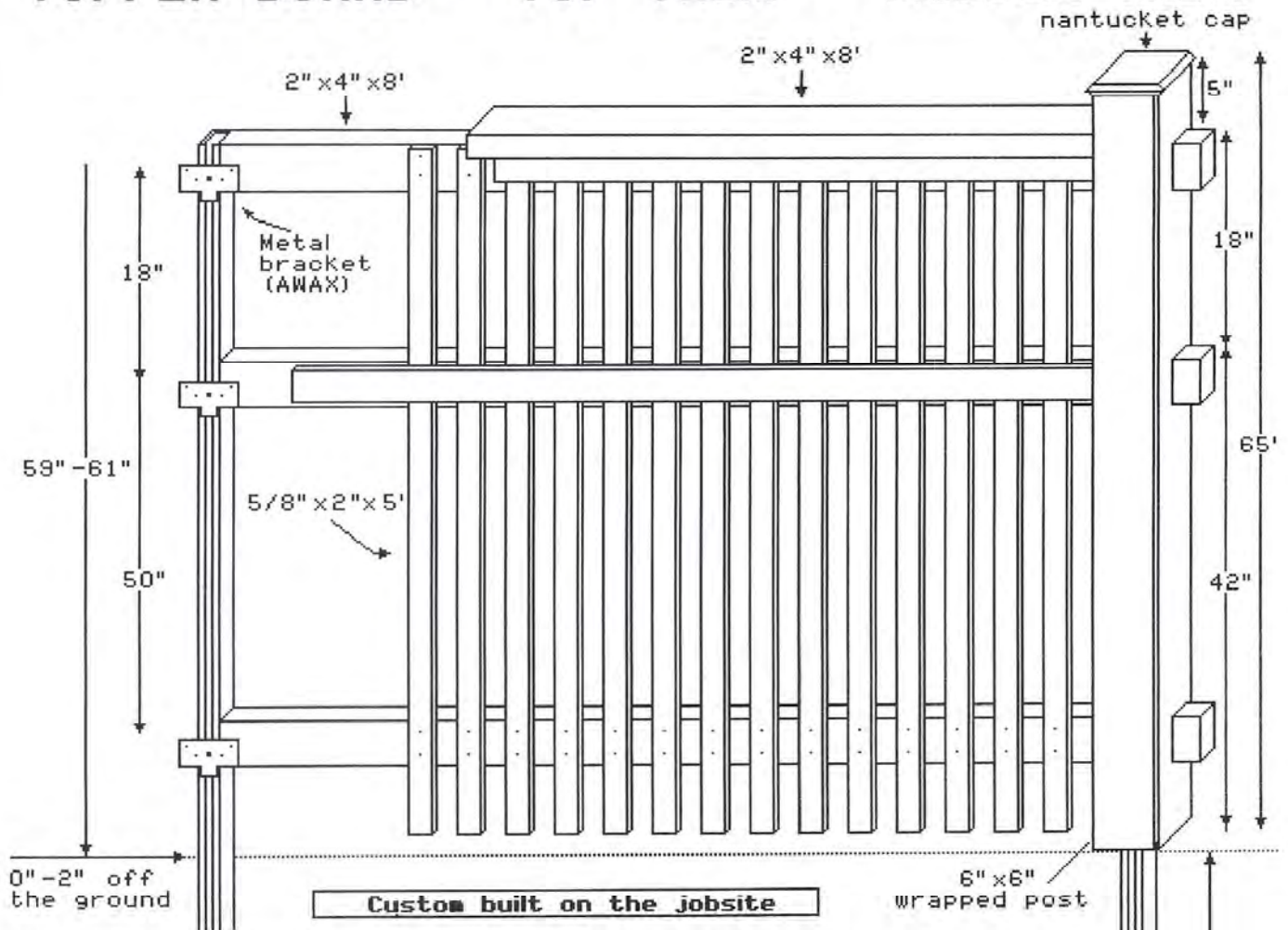

- ◆ Installed w/ 5/8" x 2" x 5' 5/8" x 6" x 5' & 5/8" x 3" x 8' western red cedar.
- ◆ Installed with 2" x 4" rough sawn western red cedar
- ◆ Installed with steel c-posts driven approx. 4' into ground equivalent to an SS40.

- ◆ Installed with metal brackets (awax) that attach to post and screw into stringers
- ◆ Installed with decorative nantucket post caps to fit 6" x 6" wrapped posts.

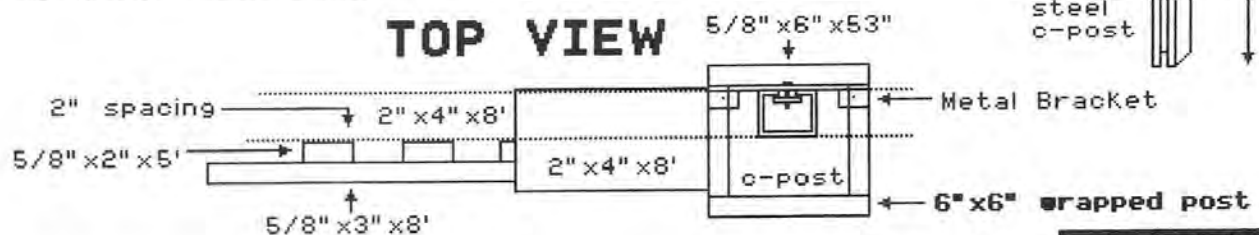

TYPE II RAIL

EXHIBIT E-3 / Type II Stick

**5' HIGH 1X2 PICKET WITH A 2" SPACE
W/ WRAPPED POSTS AND NANTUCKET CAPS
TOPPER BOARD - TOP TRIM - MIDDLE TRIM
DIAGONAL LATTICE**

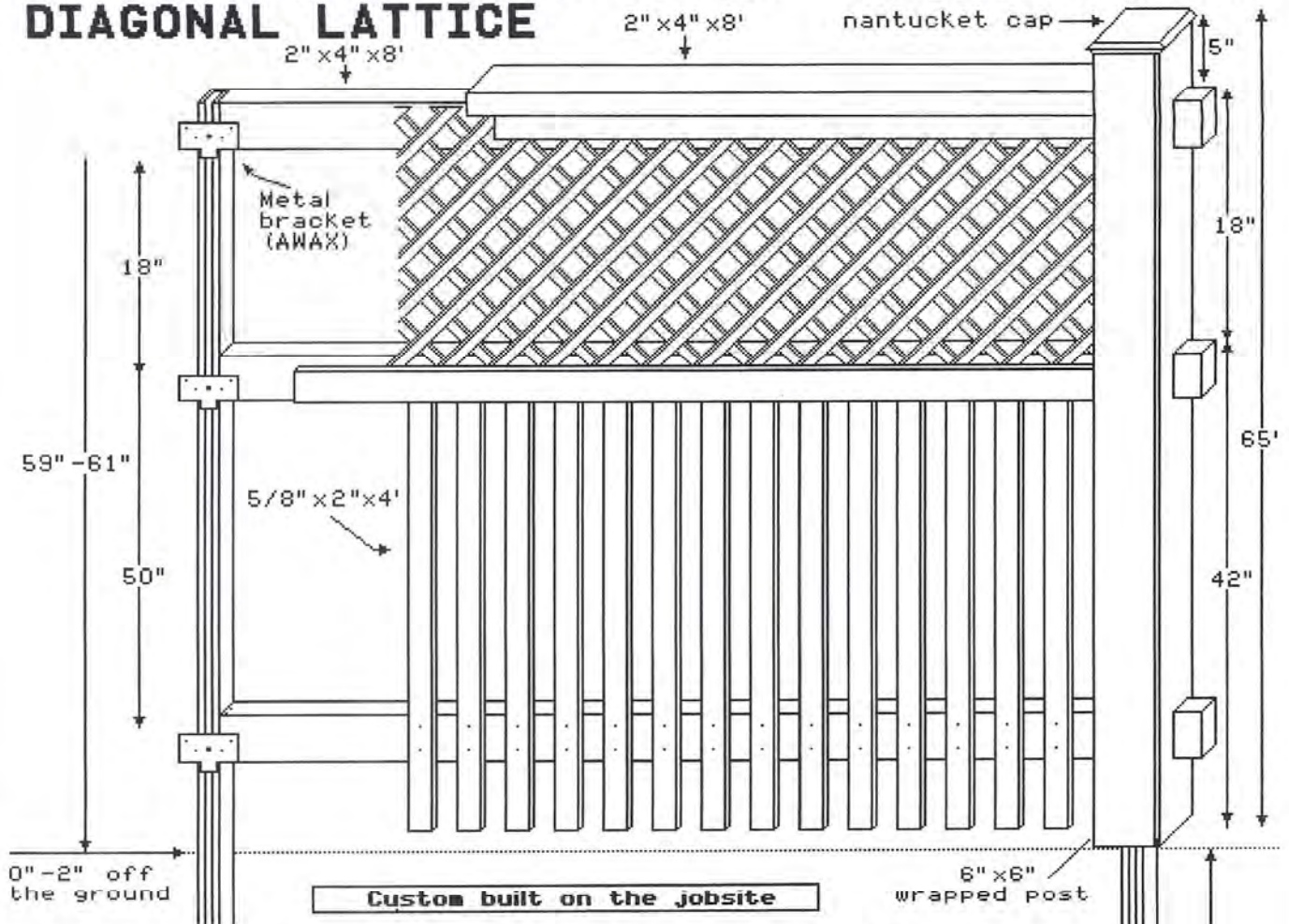

- ◆ Installed w/ 5/8" x 2" x 4' 5/8" x 6" x 5' & 5/8" x 3" x 8' western red cedar.
- ◆ Installed with 2" x 4" rough sawn western red cedar
- ◆ Installed with steel c-posts driven approx. 4' into ground equivalent to an SS40.
- ◆ Installed with metal brackets (awax) that attach to post and screw into stringers
- ◆ Installed with decorative nantucket post caps to fit 6" x 6" wrapped posts.
- ◆ Lattice will be 1 1/2" x 1/4" strips with 2 1/2" squares.

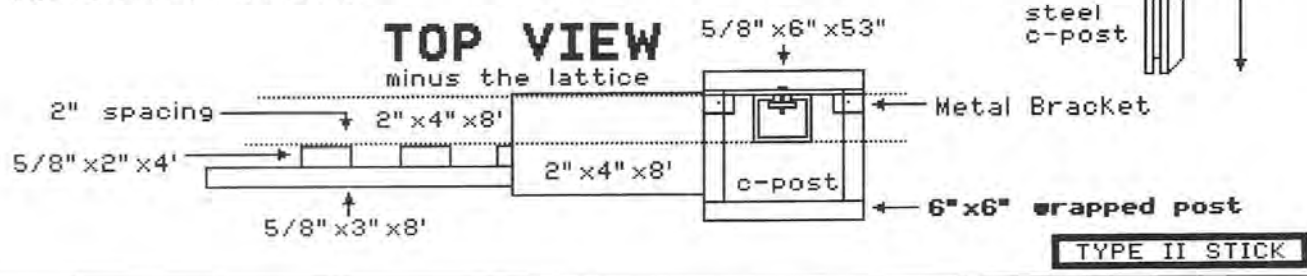
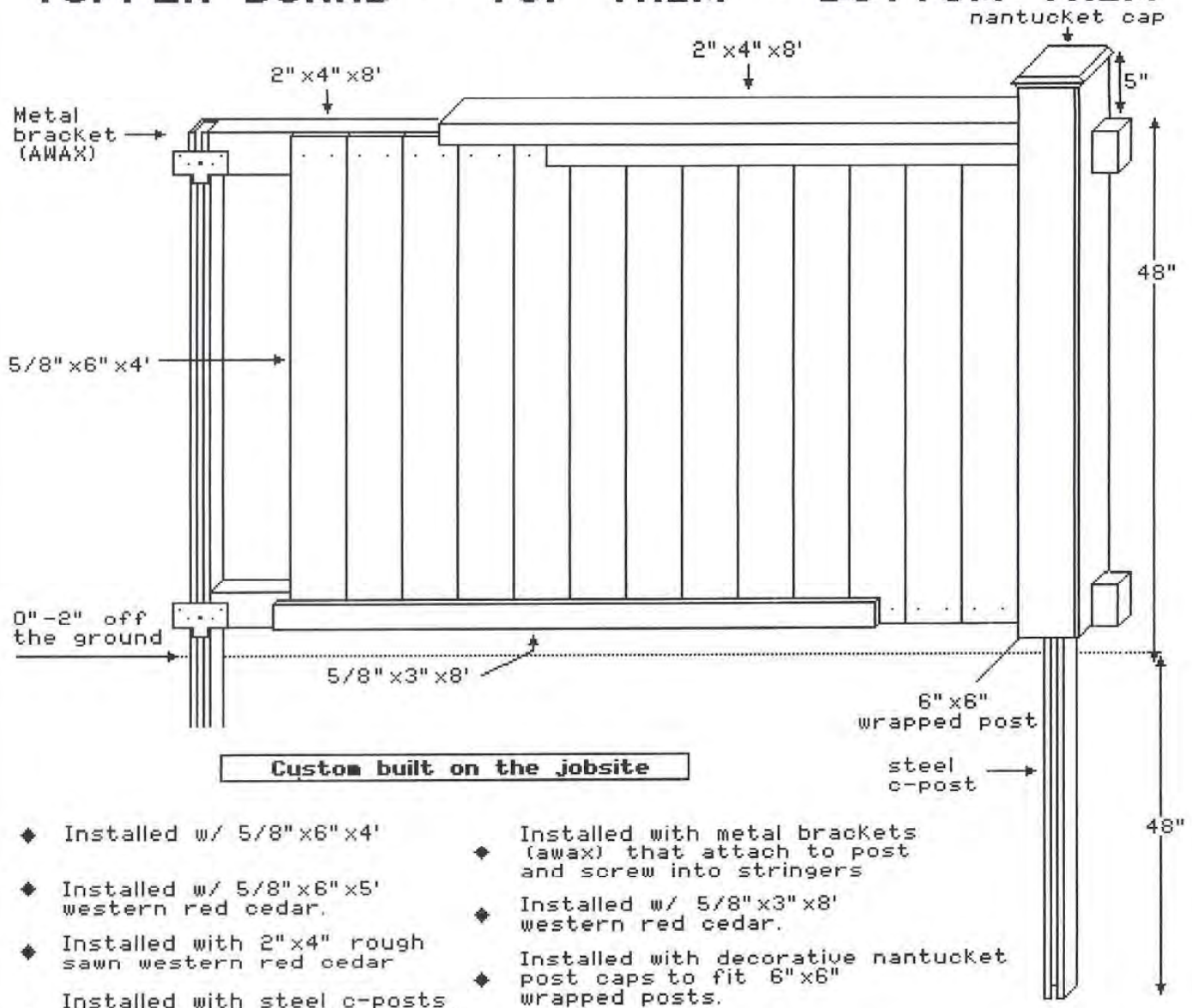
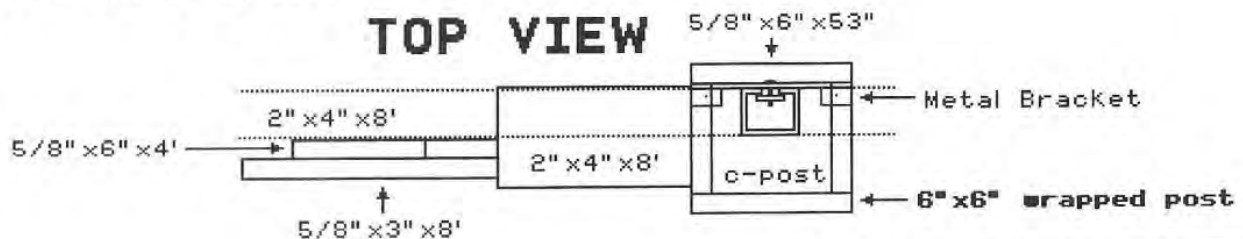

EXHIBIT E-4

4' HIGH SOLID WOOD PRAIRIE 1" X 6" W/ WRAPPED POSTS AND NANTUCKET CAPS TOPPER BOARD - TOP TRIM - BOTTOM TRIM



TOP VIEW



4' PRAIRIE W/ WRAPPED POSTS

EXHIBIT E-5 / Type I Board

4' HIGH WOOD SPACED PICKET DOG-EARED W/ WRAPPED POSTS AND NANTUCKET CAPS

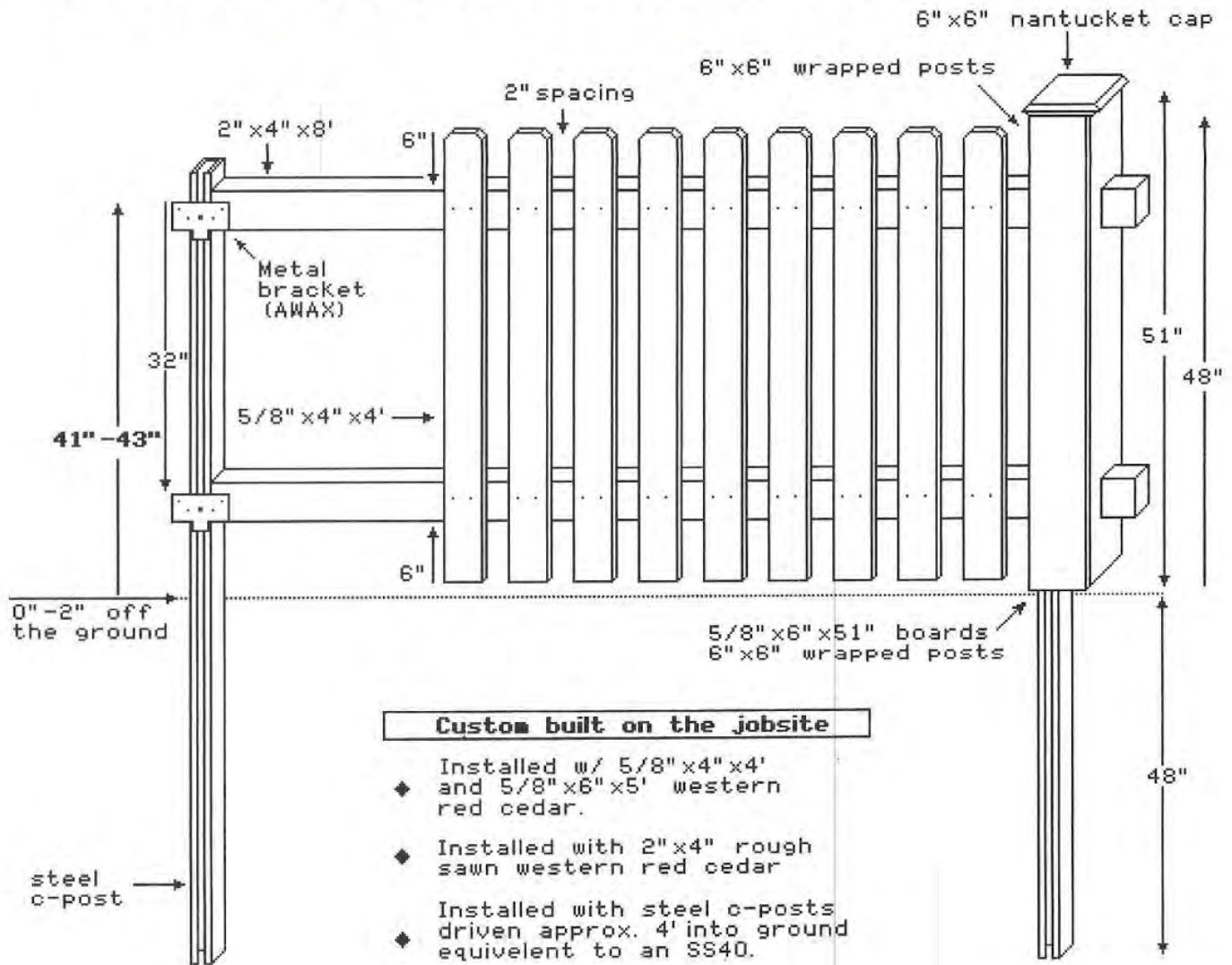

Custom built on the jobsite

- ◆ Installed w/ 5/8" x 4" x 4' and 5/8" x 6" x 5' western red cedar.
- ◆ Installed with 2" x 4" rough sawn western red cedar
- ◆ Installed with steel c-posts driven approx. 4' into ground equivalent to an SS40.
- ◆ Installed with metal brackets (awax) that attach to post and screw into stringers
- ◆ Decorative Maxima hinges and lockable Maxima latches

TOP VIEW

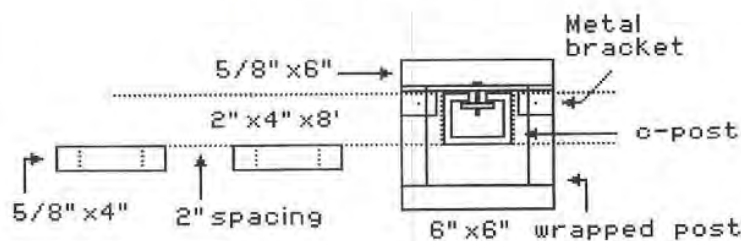

SIDE VIEW

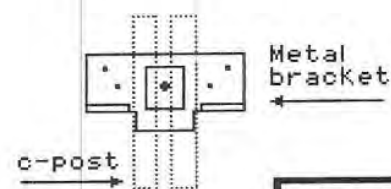

TYPE 1 BOARD

EXHIBIT E-6 / Type I Stick

4' WOOD 2" SPACED PICKET 1" X 2" X 4' W/ WRAPPED POSTS AND NANTUCKET CAPS

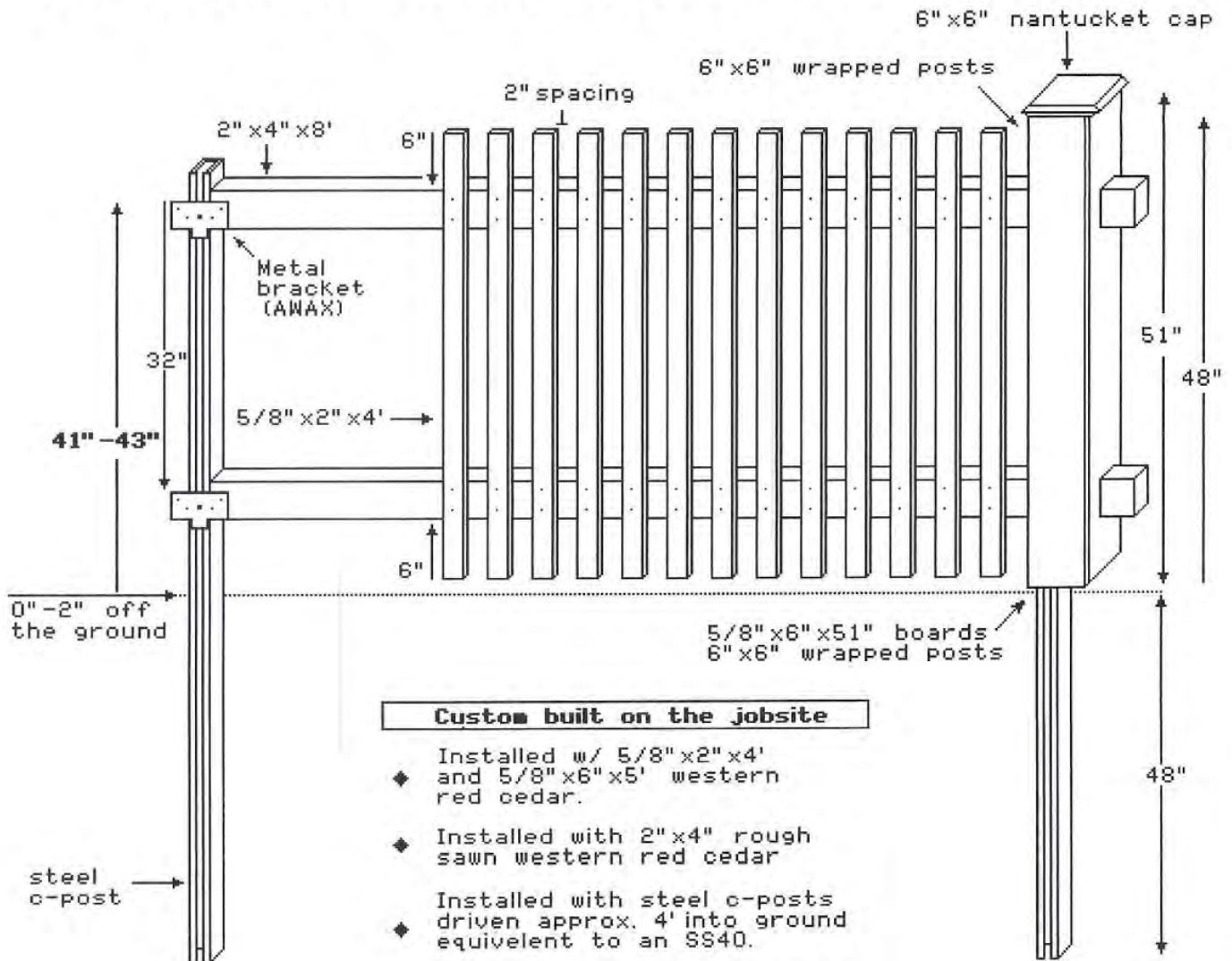

TOP VIEW

SIDE VIEW

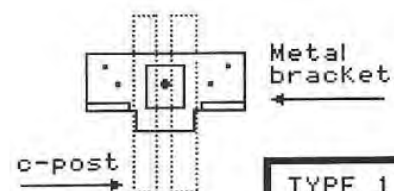
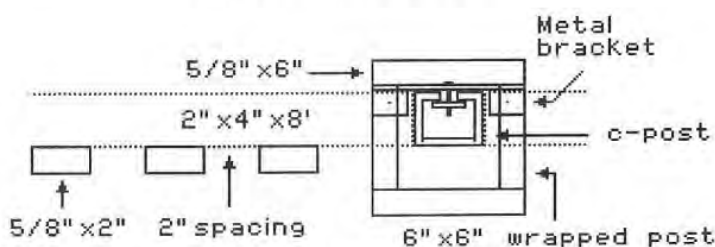

TYPE 1 STICK

EXHIBIT E-7 / Type I Picket

4' HIGH WOOD SPACED PICKET FRENCH GOTHIC W/ WRAPPED POSTS AND NANTUCKET CAPS

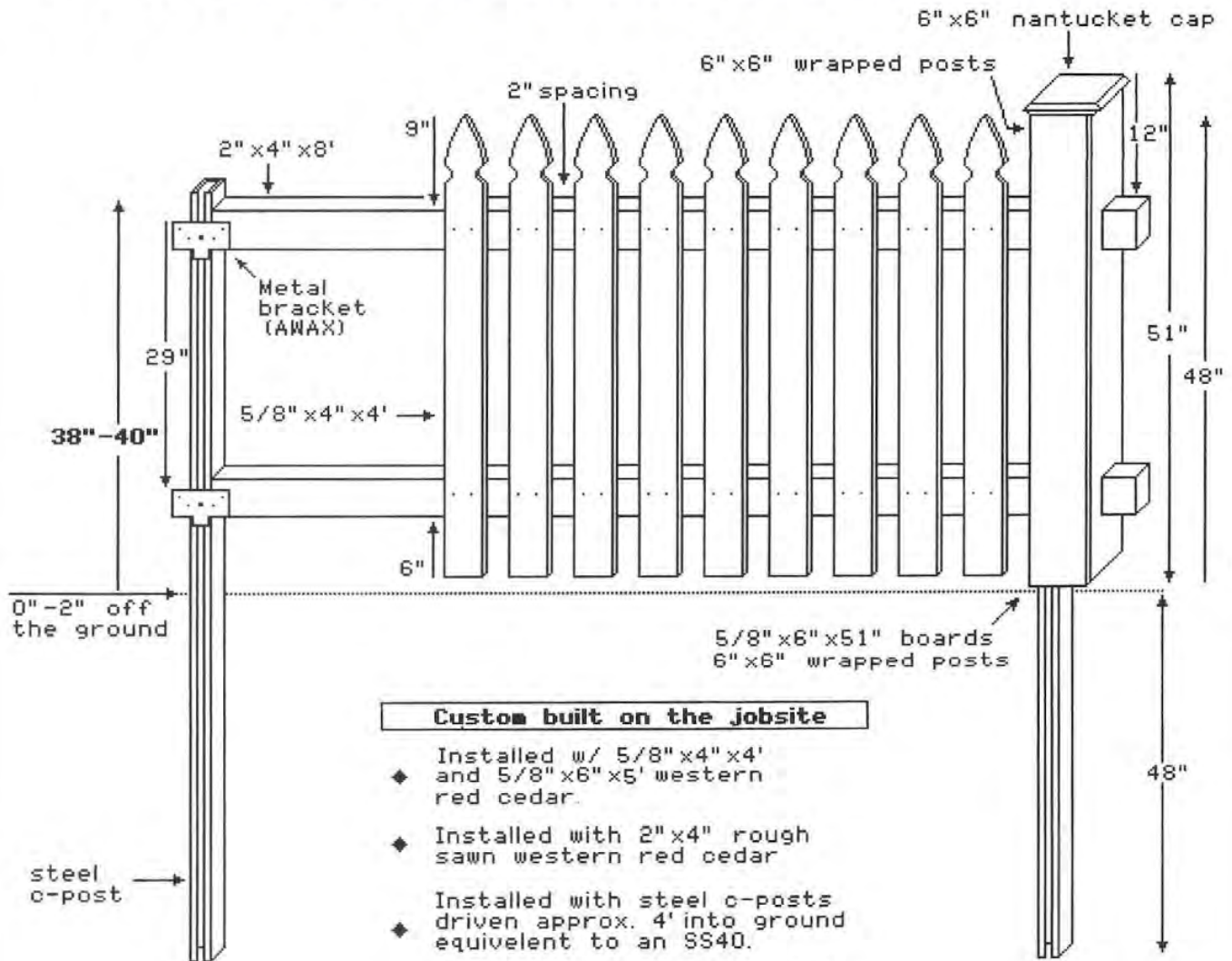

TOP VIEW

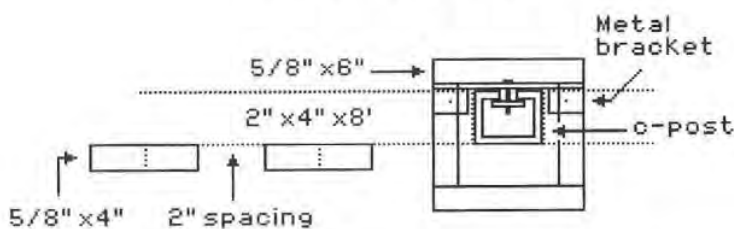

SIDE VIEW

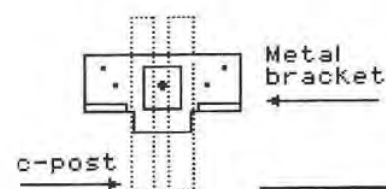

TYPE 1 PICKET

EXHIBIT E-8 / Type I Rail

4' WOOD 2" SPACED PICKET 1" X 2" X 4' W/ WRAPPED POSTS, TOPPER, TOP TRIM AND NANTUCKET CAPS

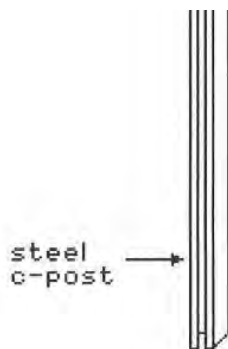
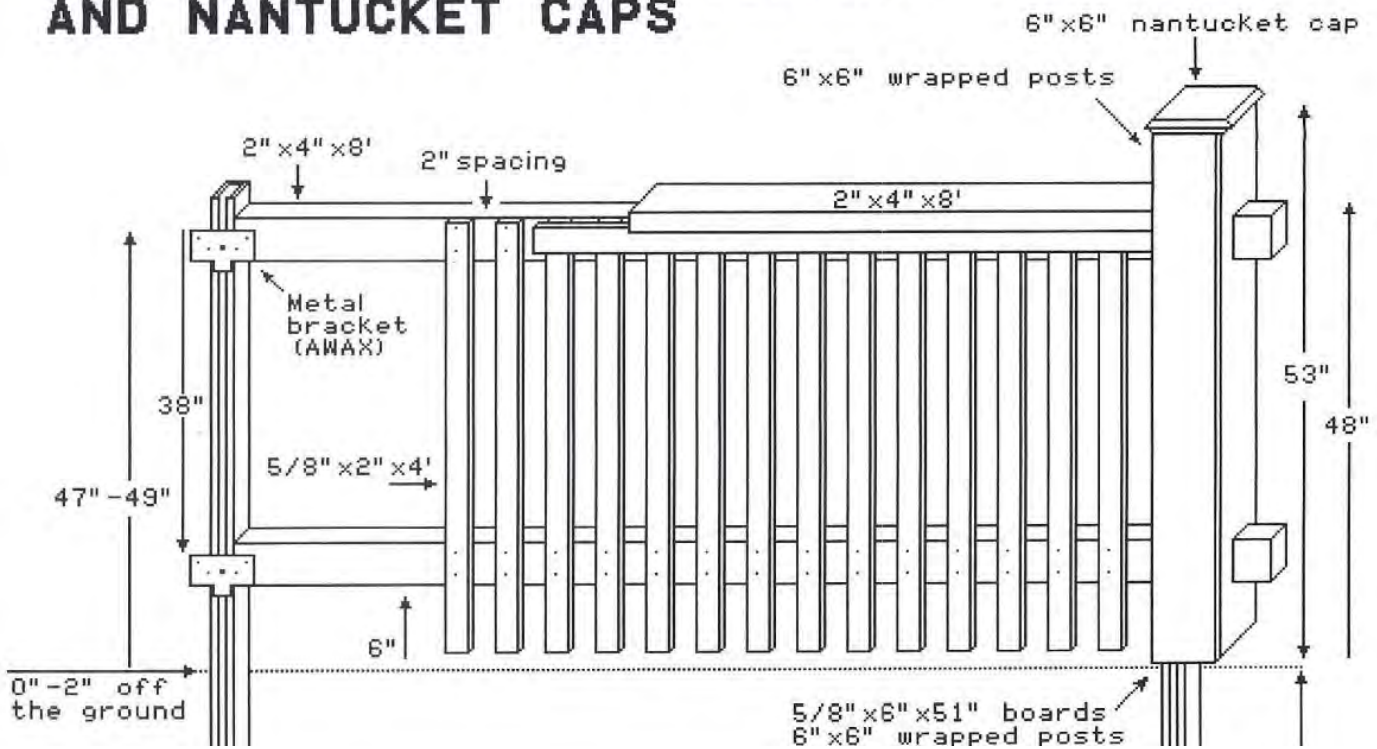

Custom built on the jobsite

- ◆ Installed w/ 5/8" x 2" x 4' and 5/8" x 6" x 5' western red cedar.
- ◆ Installed with 2" x 4" rough sawn western red cedar
- ◆ Installed with steel c-posts driven approx. 4' into ground equivalent to an SS40.
- ◆ Installed with metal brackets (awax) that attach to post and screw into stringers
- ◆ Decorative Maxima hinges and lockable Maxima latches

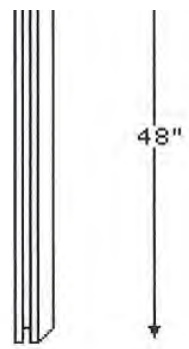

TOP VIEW

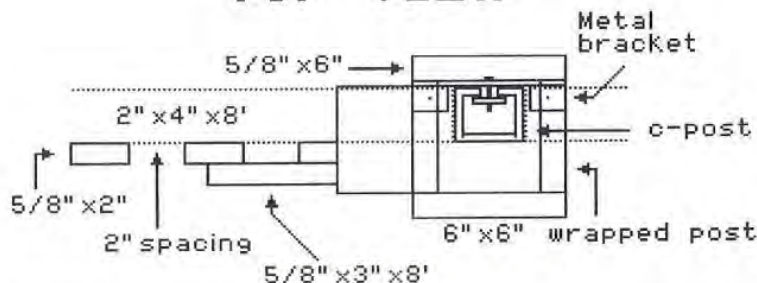

SIDE VIEW

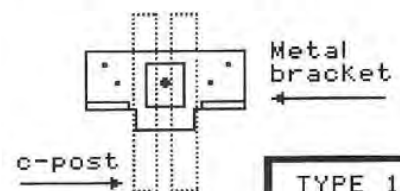

TYPE 1 RAIL

BLACK or BRONZE ONLY

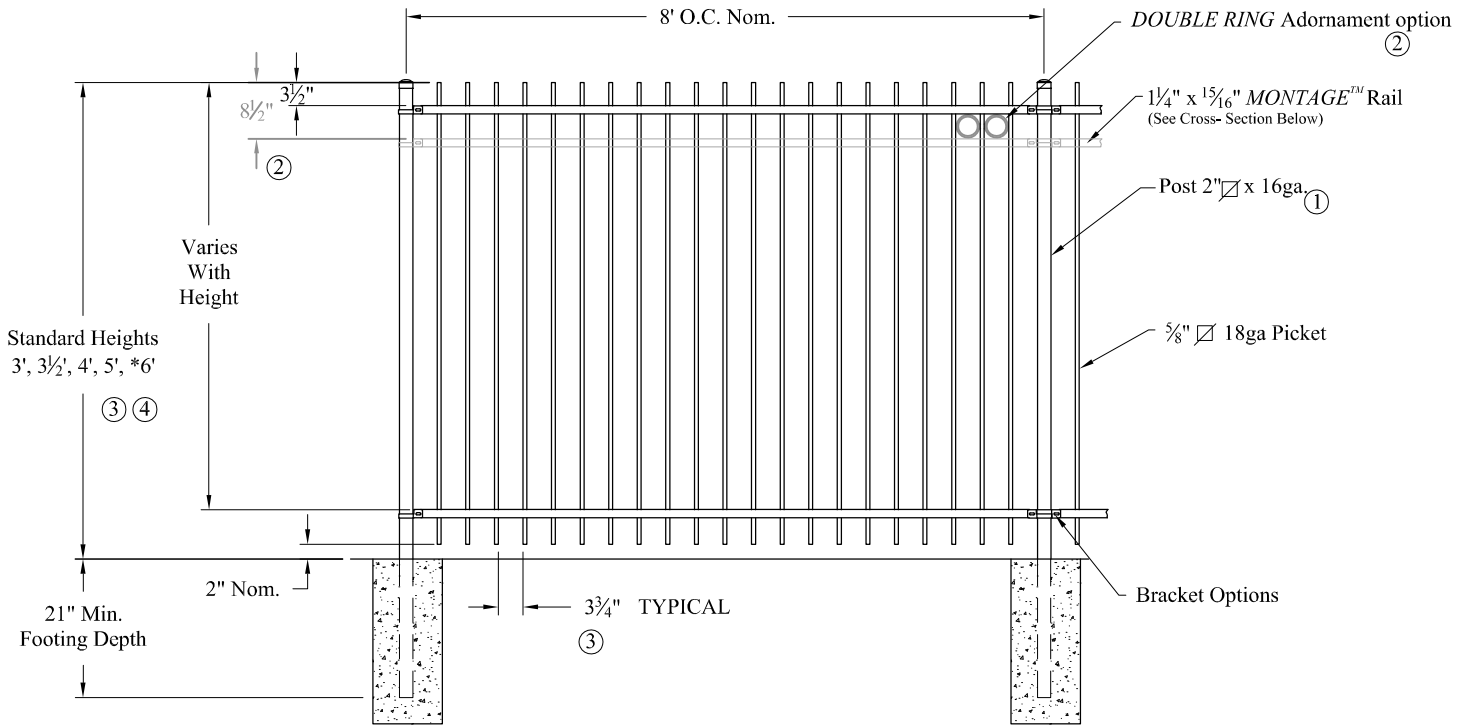

NOTES:

- 1.) Post size depends on fence height and wind loads. See MONTAGE™ specifications for post sizing chart.
- 2.) Third rail required for Double Rings.
- 3.) Available in 3" air space and/or Flush Bottom on most heights.
- 4.) Three rails required for 6' tall.

RAKING DIRECTIONAL ARROW

Welded panel can be raked 45" over 8' with arrow pointing down grade.

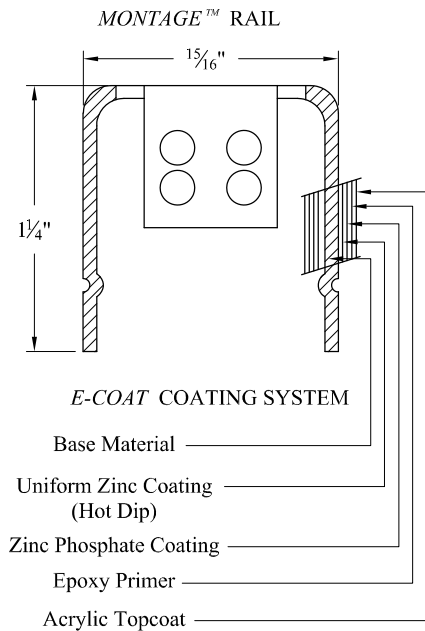

PROFUSION™ WELDING PROCESS

No exposed welds,
Good Neighbor profile - Same appearance on both sides

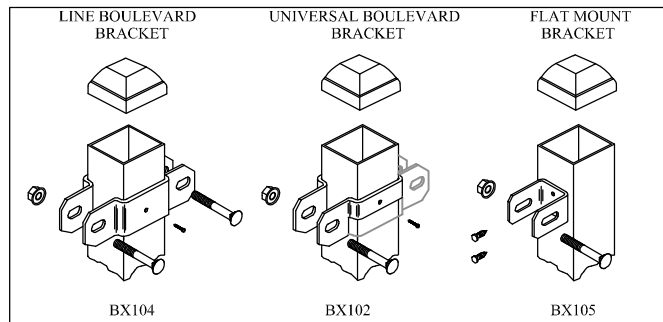
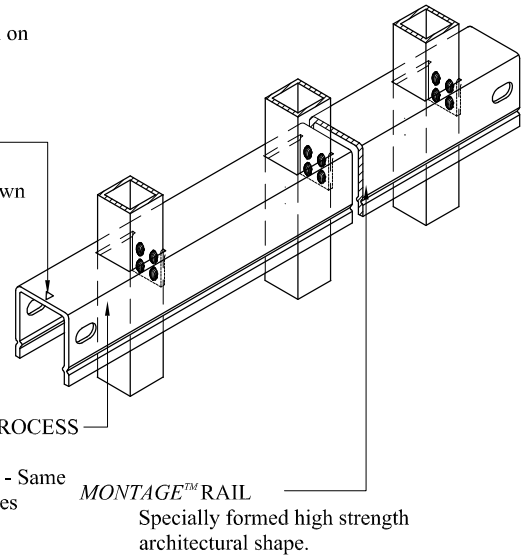

RESIDENTIAL WELDED STEEL PANEL

PRE-ASSEMBLED

Values shown are nominal and not to be used for installation purposes. See product specification for installation requirements.

RGISO

Title: **MONTAGE GENESIS 2/3-RAIL**

DR: CI SH . 1 of 1 SCALE: DO NOT SCALE

CK: ME Date 7-19-11 REV: c



AMERISTAR®

1555 N. Mingo
Tulsa, OK 74116
1-888-333-3422
www.ameristarfence.com